



BATHROOM HEATER 浴室暖風機

OPERATION MANUAL 使用說明書

RA-BH205FY

RA-BH205FW



僅適用於家庭使用 For Household Use Only

使用前請先詳細閱讀本說明書，並保存以便日後參考。

本說明書中所有圖片僅供解釋用途。

Please read this user manual before using the product and retain it for your future reference.

All the pictures in this manual are for reference only.

安全注意事項 (請務必詳細閱讀及遵守安全指導)

1. 使用本產品時，請嚴格遵守以下注意事項。
 - 不遵循或忽視這些安全注意事項會導致火災、觸電或個人傷害。
2. 用戶必須使用有安全認證的合格插座，否則，可能會引起火災的危險。
3. 此設備可供 8 歲以上兒童，肢體、感官、心智殘缺或缺乏經驗和知識的人使用，但他們必須已獲得監督和安全使用該設備的指導，並且了解其中的危害。兒童不應將本產品用於玩耍。清潔和保養，不得讓兒童在沒有監督的情況下實施。本設備是不打算供與(包括兒童)身體、感官或智力有障礙，或缺乏經驗和知識人士使用，除非他們是在負責他們安全的人員監督或有關使用該設備的指示下使用。兒童應當受到監督以確保他們不會玩耍器具。
4. 拔掉電源線插頭時須緊握，切勿拉扯電線。
5. 警告: 對於行動不便的人在狹小空間使用本產品的加熱功能時，必須有對其安全負責的人進行持續監督。
6. 為減少觸電的潛在危險，請將插頭插在正確的電源插座上。若產品的插頭與插座不能完全匹配，請諮詢專業和合資格的技術人員。
7. 確保電源插頭完全插入插座，否則會引致觸電或插頭過熱而造成火災。
8. 要定期清除電源插頭及插座上之灰塵，否則引致絕緣不良而導致火災。
9. 若電源線或插頭有裸露或有損壞時，切勿使用本機。避免危險，必須交由信興電器服務中心有限公司維修。如果電源線損壞或產品出現故障，必須交由信興電器服務中心有限公司維修，以避免危險。請勿私自拆卸、檢修，或更換非生產商提供的配件。
10. 切勿過度擰捏，彎曲或扭轉電源線，否則線芯可能會曝露在外或折斷。
11. 每次使用此產品前，請確保電源線是完全鬆開的。請避免使用延長電源線，因為延長電源線或拖板式插座可能會過熱而導致火災風險。另外，切勿在同一插座上使用多於一個產品或其他裝置，因為插座可能會負荷過重。
12. 嚴禁讓機體沾水，否則會導致漏電、短路、產品損壞及導致火災的可能。
13. 警告：為避免過熱，禁止覆蓋此產品及以任何物件遮擋進出風位。 
14. 切勿將物品放置在機體上。
15. 手濕時切勿接觸電源插頭，否則有觸電的危險。
16. 切勿讓手指或其他異物插入機體任何通風或排氣口，這可能會導致觸電、身體損傷、火災或損壞機體。
17. 本機在使用時不可用力敲擊或震動機身。
18. 請勿在戶外地方使用此產品，此產品僅供室內使用。
19. 請勿在陽光直射下使用產品。
20. 請勿覆蓋電源線，電源線要擺放好，防止行走時拌倒。
21. 產品要放在平坦堅實的地面上工作，確保產品運轉時不會碰到障礙物，以免產品翻倒。

22. 此產品運轉時，請勿將頭髮、窗簾或門簾等柔軟物件貼近本產品，以免捲入機內，發生危險。
23. 嚴禁在以下場所使用此產品：接近氣體爐具/有易燃氣體的地方/有雨淋或容易被滴水的地方/接近殺蟲劑的地方/油性的腐蝕性溶劑附近/高溫的地方/潮濕的地方/在化學物品、油、多塵的地方。
24. 機體上方不可掛滴水的衣物或受到雨淋，避免進水發生漏電及觸電危險。嚴禁將可燃物及未乾的衣物覆蓋在機器出風口上，避免發生火災或觸電危險。
25. 請勿在產品周圍噴灑清潔溶劑及可燃性噴霧劑，否則可能使產品受損。
26. 請勿在浴缸、花灑頭或游泳池的範圍使用。
27. 如產品曾經跌落，請勿使用。
28. 為了安全起見，當人離開產品時，必須關機，以免發生意外。當沒有人使用此產品時，請拔除電源。
29. 產品不得直接置於電源插座下面。
30. 避免將產品出風口長時間或直接向嬰幼兒吹風。
31. 產品清潔，檢修或移除面蓋前必須先切斷電源並拔掉電源線插頭。
32. 產品外殼清潔時，應用濕布(或加少許洗潔精)抹擦，不要用有腐蝕性的洗滌劑或溶劑之類清潔，嚴禁用水沖(淋)洗。
33. 警告：為降低火災風險，不可將本機進、出風口貼近牆壁、窗簾等物品。將紡織品窗簾或任何其他易燃材料與產品出風口保持至少 1 米的距離。
34. 本機在使用一段時間後，若出現異聲或風速不均勻的現象，可能是後殼進風口處的灰塵太多阻塞了氣流，此時用毛刷清潔一下後即可恢復正常。
35. 產品長期不使用時，應拔下電源插頭，包好本機防止灰塵進入機內，並放置乾燥通風處存放。
36. 3 歲以下兒童需在家長陪同和監督下接觸本產品。
37. 當本產品被放置或安裝在正常工作位置時、在有對其安全負責的人的指導或協助、並確保使用者的安全及其明白當中潛在危險的前提下，3 至 8 歲的兒童只可開啟/關閉本產品。3 至 8 歲的兒童不可調節、清潔、保養本產品，亦不可把本產品的插頭連接電源。
38. 在操作面板損壞時不得使用。
39. 注意：本產品的某些部位使用時會變得非常熱，並可能導致燙傷，兒童及易受傷害人士應特別注意。
40. 產品的開關和其他控制裝置應安裝在使用浴缸或淋浴時不能接觸到的地方。

部件名稱

- | | | |
|-----------|--------------|--------------|
| 1. 提手/掛臂 | 9. 1小時定時指示燈 | 17. 定時按鍵 |
| 2. 功能面板 | 10. 4小時定時指示燈 | 18. 常風/暖風選擇鍵 |
| 3. 毛巾架 | 11. 常溫風指示燈 | 19. 暖風高/低選擇鍵 |
| 4. 主電源開/關 | 12. 高暖風指示燈 | 20. 開機關機鍵 |
| 5. 電源線 | 13. 低暖風指示燈 | 21. 掛架組件 |
| 6. 螺絲孔 | 14. 遙控接收器 | 22. 掛牆組件 |
| 7. 掛牆支架孔 | 15. 8小時定時指示燈 | 23. 遙控器 |
| 8. 濾塵網 | 16. 2小時定時指示燈 | 24. 掛牆螺絲 |

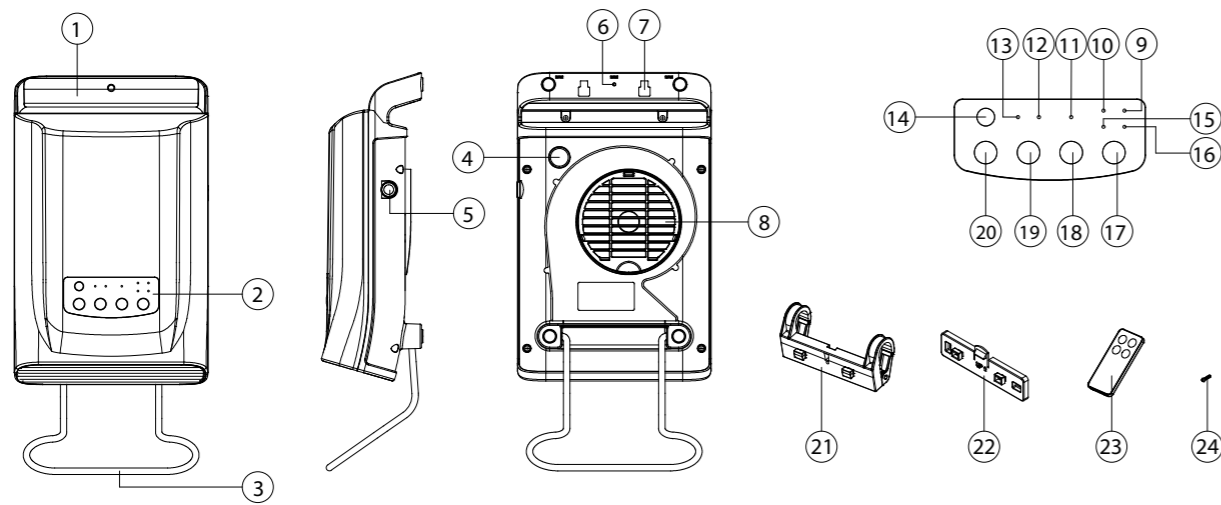

包裝附件表

圖號	名稱及用途	數量
①	自攻螺絲4x28(打掛牆組件用)	2
②	膨脹膠粒	2
③	掛牆組件	1
④	掛架組件	1
⑤	毛巾掛架	1
⑥	遙控器	1
⑦	機械螺絲4x18(打掛架組件用)	1

安裝方法

1. 座檯使用

置放於穩定的平面上使用。
注意：請勿覆蓋及踐踏。

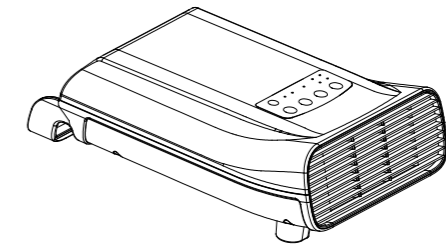

2. 掛牆使用 (產品在浴室使用時僅允許固定安裝在牆壁上)

按照下圖所示，於牆上鑽兩個開孔(相距 12cm)，安裝掛牆組件於牆上，以螺絲固定，將產品掛於牆上。

注意：1. 安裝要求：產品離地面距離至少 1 米及距離左邊或右邊牆壁至少 0.3 米，距離水源至少 1.2 米。

2. 安裝必需牢固可靠，以防機器鬆動脫落！

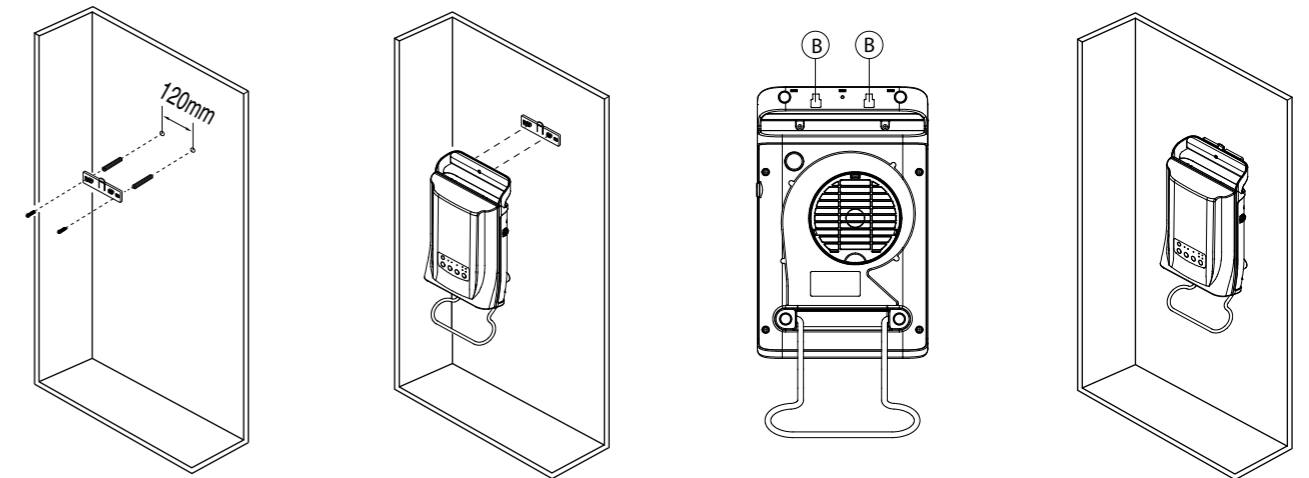

拆除掛牆產品

如需取下產品，先按下掛牆組件上的彈扣，再把產品向上輕托起即可取出產品。

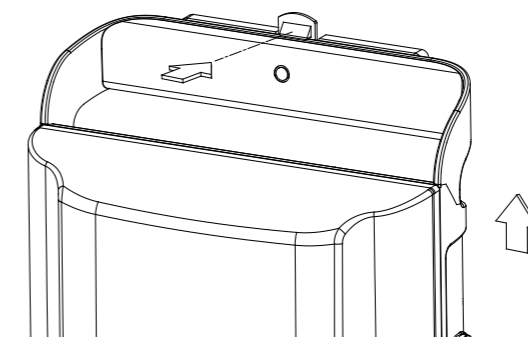

3. 懸掛使用

將掛架組件安裝在提手/掛臂上，以螺絲固定掛架組件。撥開掛架組件的活動扣位，將產品掛於穩固的掛架上，距離背後牆身至少 5 cm。

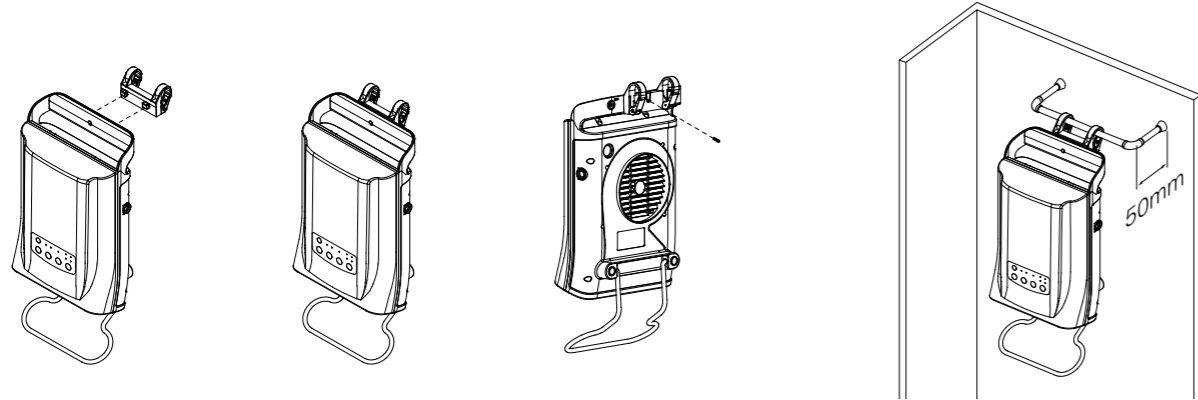

注意：請勿在產品背面安放毛巾、紙片等雜物，以避免遮擋進風口。

4. 毛巾架安裝

按下圖所示，把毛巾架裝入機背相應的插孔，套緊後向下拉固定。

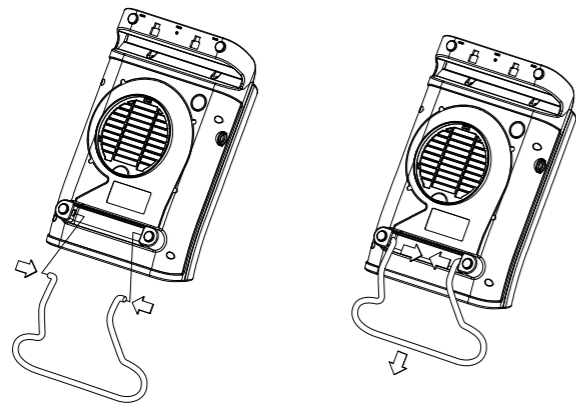

操作及顯示面板

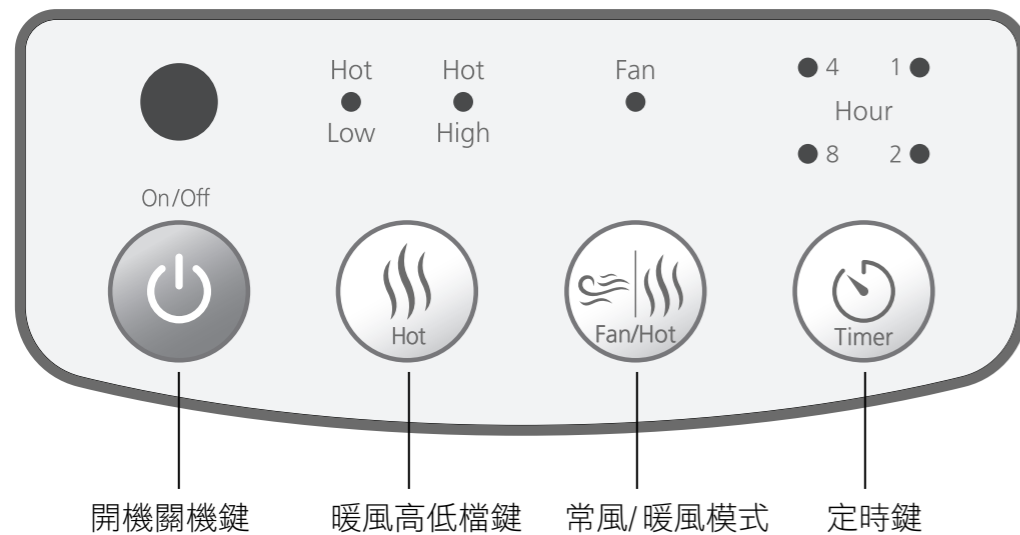

遙控器



更換遙控器電池

- ① 遙控器背面有一個電池盒。請在壓下電池盒側面的同時將其拉出。
- ② 正面朝上 放入硬幣形鋰電池 (CR2032 3V)。
- ③ 放入電池後，滑動電池盒，然後插入並固定電池盒。

清潔和保養

拆卸濾塵網和濾塵網蓋

步驟：將凸槽拉向自己，將濾塵網和濾塵網蓋拆出。

警告：1. 移動、清潔及保養產品前須先關掉電器，拔除插頭並待其冷卻。

2. 取下濾塵網蓋和濾塵網後切勿通電開機。

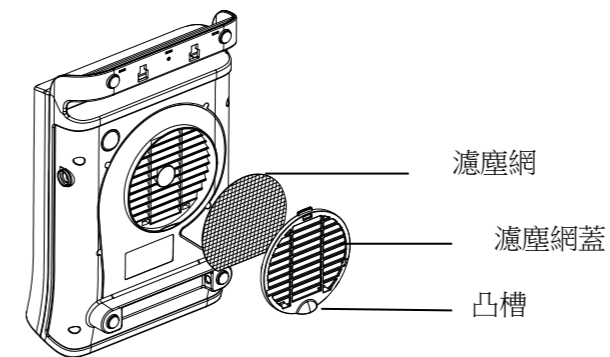

清潔濾塵網和濾塵網蓋

- 清潔、保養或移動產品前，必須先關閉產品，然後拔除電源插頭並待其冷卻。
- 機體外部有污跡的地方，可以用中性清潔劑沾微濕布擦拭乾淨即可。
- 切勿將電源線、插頭或主機浸在水中清潔或在水龍頭下沖洗。
- 切勿使用鋼絲刷、汽油、火酒、酒精、醋或其他揮發、有毒或含腐蝕性液體清潔產品，以免損壞產品。
- 隔塵網用清水沖洗乾淨即可，清潔完畢後隔塵網必須完全乾透才可裝回使用。
- 清潔完畢，必須待產品完全乾透，才可連接電源使用。
- 如長時間不使用產品，請將產品收藏回包裝盒內並放置在乾燥陰涼且安全的地方。



操作說明

把電源插頭連接到一個獨立的電源插座上(220-240V~ 50Hz)。按下產品後面的電源總開關到“|”位置開機 蜂鳴器響起(Bi B兩聲)。

開機關機鍵

當按下開機關機鍵 ，產品開啟默認為熱風低檔狀態，熱風低檔紅色指示燈亮起。

暖風高低選擇鍵

當按下暖風高低鍵 ，開始低檔暖風運行，低檔紅色指示燈亮起。再次按下  高檔工作，高檔紅色指示燈亮起。

注:若在暖風狀態下關機，機器會延遲約 10 秒才停機。

常風/暖風選擇模式

當按下常風/暖風選擇鍵 ，選擇常風功能及暖風功能。
常風模式指示燈為藍色，而暖風模式指示燈為紅色。

定時鍵

當按下定時鍵  開啟定時功能，相應定時紅色指示燈亮，可任意選擇 1-2-4-8 小時設置。連續按此鍵，指示燈熄滅。

常見故障及排除

注意：非專業人員請勿拆解、維修本產品。

	故障現象	故障原因	處理
①	加熱器不工作	停電或插頭未插好	檢查電路或重插插頭
②	無熱風輸出(功能按鍵及指示器正常)	出風口有阻礙物	取走阻礙物
③	風量變小	濾塵網堵塞	清洗濾塵網
④	無風輸出(功能按鍵及指示器正常)	濾塵網嚴重堵塞	清洗濾塵網
⑤	遙控器無法操作	操作前未有把電池絕緣膠片除掉	除掉電池絕緣膠片
		電池電量不足	更換電池
⑥	其他故障	不明原因	請聯繫信興電器服務中心

規格

產品型號	RA-BH205FW / RA-BH205FY
顏色	白色 / 灰色
額定電壓	220-240V 伏特~
額定頻率	50 赫茲
額定功率	2050 瓦
外型尺寸(寬×深×高)	240 x 127 x 383 毫米
淨重	2.2 公斤

特別聲明

1. 本資料上所有內容經過認真核對，如有任何印刷及內容上的誤解，本公司將保留解釋權。
2. 本產品若有技術改進，會編進新版說明書中，恕不另行通知；產品外觀及顏色如有改動，則以實物為準。
3. 用戶如需要電子版使用說明書，請致電信興電工工程有限公司熱線查詢：2861 2767。

售後服務

由購買日期起之一年保修期內，經信興電器服務中心有限公司之服務人員證實乃在正常使用之情況下發生者，本公司將提供免費修理及更換零件。經更換之任何損壞零件，將歸屬本公司。保修範圍不包括修理或更換產品之附件、電源線及機殼等，如有需要服務時，用戶須另付費用。用戶請於維修時出示購買收據 / 換購收據及保修證，如有任何疑問，請致電信興電器服務中心有限公司熱線查詢：2406 5666。

如在保修證內所列之電器：1.) 曾經被非本公司技術人員明顯地或非明顯地進行改裝、更改或修理；或 2) 曾經被錯誤或不適當或疏忽使用、或因液體浸蝕、水濺、不正常供電、天災、意外或外來因素造成損壞；或 3) 並非安裝在陸上固定地點；或 4) 不當安裝位置影響正常操作；或 5) 非工商業用型號產品，被用作工商業用途；或 6) 用戶搬遷地址或更換物主而未能及時通知信興電器服務中心有限公司者，保修證將自動失效。

SAFETY PRECAUTIONS (Be sure to read carefully and follow these safety directions)

1. Please observe the following safety precautions when using this appliance:
 - Failure or negligence in observing these safety precautions could cause fire, electric shock or personal injury.
2. The user must use qualified socket with safety certification, or it may cause fire.
3. This appliance can be used by children aged from 8 years and above and persons with reduced physical, sensory or mental capabilities or lack of experience and knowledge if they have been given supervision or instruction concerning use of the appliance in a safe way and understand the hazards involved. Children shall not play with the appliance. Cleaning and user maintenance shall not be made by children without supervision.
4. Hold the plug when disconnect from the power supply, never pull the supply cord.
5. **WARNING:** Do not use this appliance in small rooms when they are occupied by persons not capable of leaving the room on their own, unless constant supervision is provided.
6. To reduce the risk of electric shock, this plug is intended to fit in a correct outlet. If the plug of heater does not fit fully in the outlet, please contact a qualified electrician.
7. Make sure plug is fully inserted into socket. Loose engagement of main plug and socket may cause electric shock or fire due to overheating of the main plug.
8. Wipe off dust on the plug and socket periodically. Accumulation of dust on main plug may cause poor insulation and may result in fire.
9. Do not use the appliance when the power cord or plug is damaged. If the supply cord is damaged, it must be replaced by the Shun Hing Electric Service Centre Limited in order to avoid the hazard. If the power cord was damaged or the fan was malfunction, please take the appliance to Shun Hing Electric Service Centre Limited for repairing, please do not dismount, repair or replace with parts and accessories without authorities.
10. Do not pinch, bend, or twist the power cord excessively. The core conductors may be exposed or broken which may cause electric shock, short circuit, fire and product damage.
11. Fully unwind the lead each time before use. Where possible, avoid using of extension cords because the extension cord may overheat and cause a risk of fire. Never use a single extension cord to operate more than one heater. And make sure no other appliances are plugged into the same circuit with this heater. Otherwise, a circuit overload could occur.
12. Do not contact with water. It may cause short circuit, product damage, fire and electric shock.
13. **WARNING:** To avoid overheating, do not cover the heater and obstruct any of the heat outlet grilles or air intake openings of the heater. 
14. Please do not put any object on the appliance.
15. Never touch the appliance with wet hands to avoid electric shock.
16. Do not insert fingers or conductive object into the front and back air outlets of the machine to avoid the risk of human injury, electric shock, fire and product damage.
17. Avoid any shocks or concussions to the appliance.
18. Do not use the appliance outdoors, it is for indoor use only.
19. Do not use the appliance in the sunshine.

20. Put the power cord correctly to prevent users from tripping over the cord.
21. Put the appliance on the flat and stable ground, and make sure that the appliance does not encounter any obstructions when using the appliance.
22. Do not put soft objects such as hair or curtains close to the appliance to avoid getting caught in the heater when using the appliance.
23. Do not use the appliance under the following situation: Near gaseous fuel cooker/ Place full of inflammable gas/ Place expose to rain or water pour/ Near insecticide/ Oil corrosive solvent/ High temperature/ High humidity/ Near chemistry, oil, dust area
24. Please do not pour water into the machine or hang wet clothes over the machine so as to avoid current leakage and electric shock; Please do not put flammable materials and wet clothes covered on the air outlet so as to avoid risk of fire or electric shock.
25. Please do not spray solvent or flammable liquid to the appliance as it may cause damage to the appliance.
26. Do not use this appliance in the immediate surroundings of a bath, a shower or a swimming pool.
27. Do not use this appliance if it has been dropped.
28. Please shut down the appliance before the user leave the appliance so as to avoid accidents. Please unplug the power when not in use.
29. Appliance is not located immediately below a socket-outlet.
30. Avoid continuously exposure of direct wind from the appliance especially to infant and children.
31. The power must be cut off and unplugged before cleaning or maintenance. Ensure that the appliance is switched off from the supply main before removing cover.
32. Please clean the machine by using a damp cloth with some mild detergent, do not use corrosive detergent or solvent and similar cleaning products. Do not pour water into the machine.
33. **WARNING:** to reduce the risk of fire, please do not put the air intake and outlet of the appliance close to the wall or curtain. Keep textiles curtains, or any other flammable material a minimum distance of 1 meter from the air outlet.
34. If it occurs problems of abnormal sound or uneven wind speed after using for some time, perhaps there is too much dust in the air intake grid and make the air flow blocked, the fan could get right by cleaning the fan with a plastic brush.
35. Cut off the power if the unit is not used for a long period of time. Pull out the plug, pack the appliance well to protect it away from dust and keep it in the dry, well-ventilated and clean place.
36. Children of less than 3 years should be kept away unless continuously supervised.
37. Children aged from 3 years and less than 8 years shall only switch on/off the appliance provided that it has been placed or installed in its intended normal operating position and they have been given supervision or instruction concerning use of the appliance in a safe way and understand the hazards involved. Children aged from 3 years and less than 8 years shall not plug in, regulate and clean the appliance or perform user maintenance.
38. The appliance must not be used if the control panels are damaged.
39. **CAUTION** - After use, some parts of this product can become very hot and cause burns. Particular attention has to be given where children and vulnerable people are present.

40. The product is to be installed so that switches and other controls cannot be touched by a person in the bath or shower.

Parts name

- | | | |
|-----------------------|---------------------------------|---------------------------|
| 1. Handle & Hanger | 9. Timer Indicator Light (1H) | 17. Timer Button |
| 2. Control Panel | 10. Timer Indicator Light (4H) | 18. Fan / Heat Button |
| 3. Rail | 11. Fan Indicator Light | 19. Heat High/Low Button |
| 4. Main Power Switch | 12. Heat (High) Indicator Light | 20. ON/OFF Button |
| 5. Power Cord | 13. Heat (Low) Indicator Light | 21. Hook Mounting Bracket |
| 6. Screw Holes | 14. Remote Control Receiver | 22. Wall Mounting bracket |
| 7. Wall Mounting Hole | 15. Timer Indicator Light (8H) | 23. Remote Controller |
| 8. Air Filter | 16. Timer Indicator Light (2H) | 24. Wall Screw |

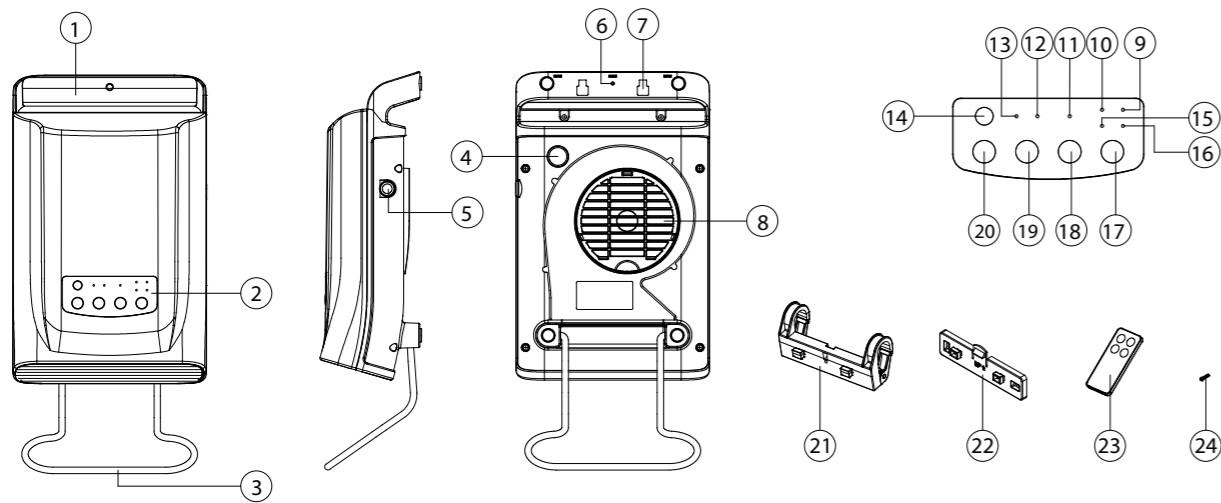

Packing accessories list

	Drawing	Name and purpose	QTY
①		Self-tapping screws 4x28 (for wall mounting)	2
②		Colloidal particles	2
③		Wall mounting bracket	1
④		Rack mounting hook	1
⑤		Rail	1
⑥		Remote control	1
⑦		Mechanical screws 4x18 (for hook mounting)	1

Installation

1. For desk use

Place on a stable and even surface.

Warning: Do not cover or step on the product.

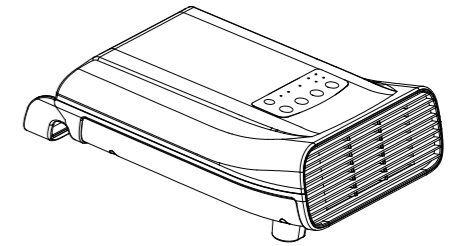

2. For wall mounting (The appliance is only allowed to be installed on the wall when used in the bathroom).

As shown below picture, drill two holes on wall (12cm apart), install the wall mount bracket to the wall and fixed by screw, mount the product on wall.

CAUTION: 1. Installation requirement: appliance height from the ground should be at least 1 meter and distance from the left or right wall should be at least 0.3 meter, at least 1.2 meter from the water source.

2. The installation must be firm and able to prevent the appliance from loosening and falling off.

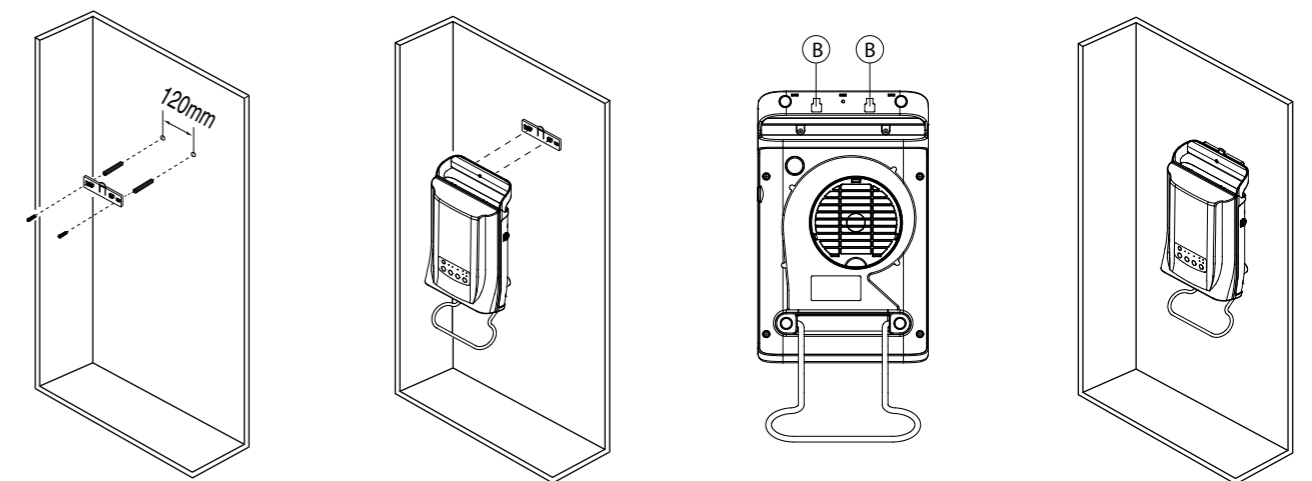

Wall-mount removal

Please push down hook on wall mounting bracket and slightly lift up appliance to take it out.

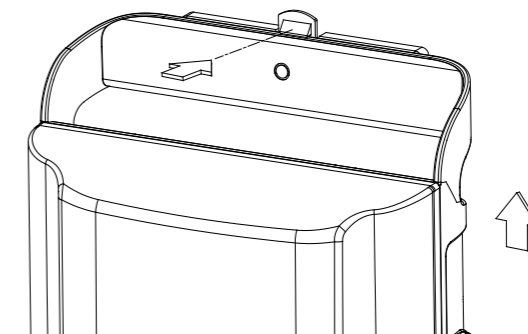

3. For hook mounting

Install the rack mounting hook onto the handle/hanger of the appliance, fasten the rack mounting hook with screw. Hang the appliance to a rack, distance from the back wall should be at least 5cm.

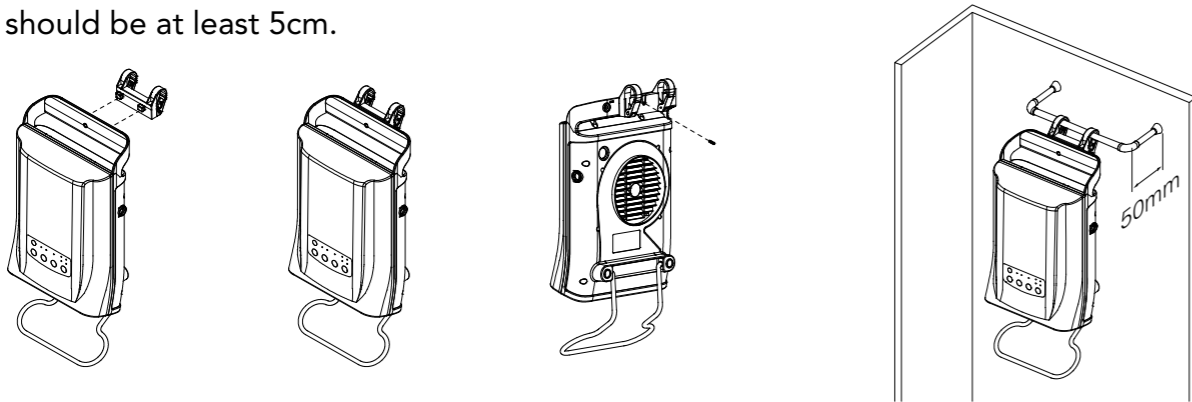

WARNING: To avoid blocking the air inlet, be careful not to put towels, paper pieces or any sundries on the back of the appliance.

4. Rack installation

As shown below picture, insert the rail into the joints on the back of the product, pull down the rail to fix it.

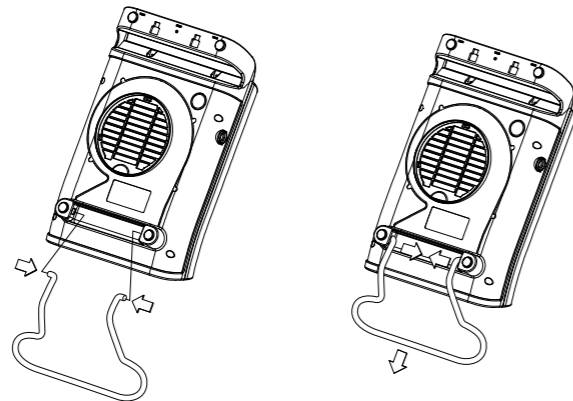

Control panel

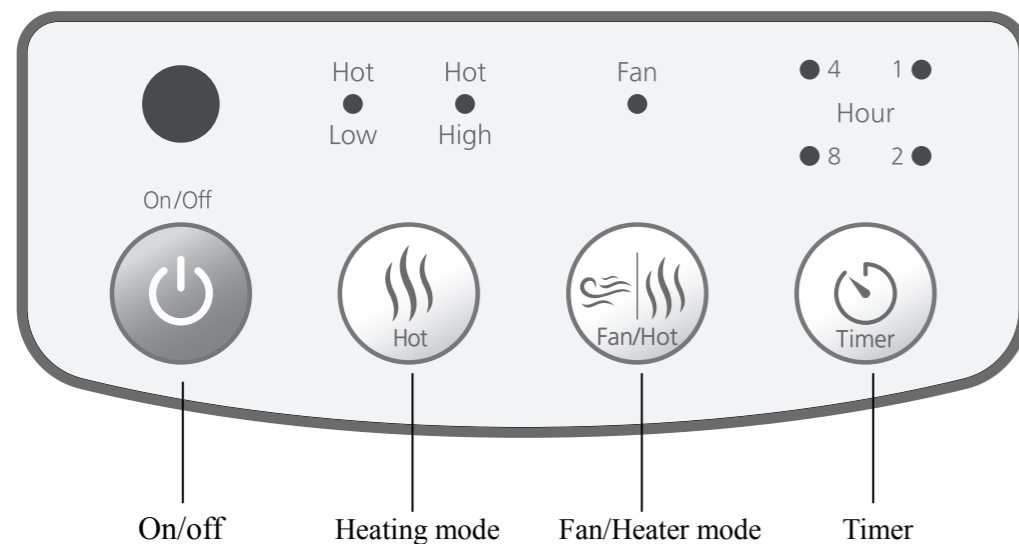

Controller remote

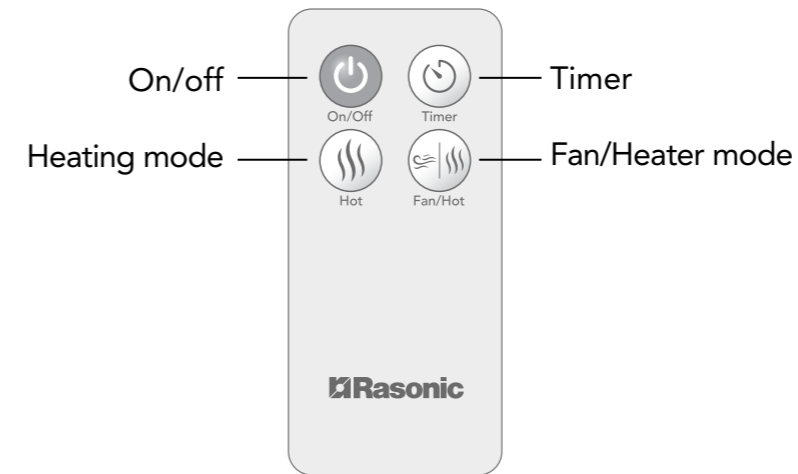

Battery replacement

- ① Pull out the battery case from the main body of the remote control and pull out the battery holder from the gap.
- ② Insert lithium battery (CR2032 3V), keep the positive pole upwards.
- ③ After inserting the battery, slide the battery box, then insert and fix the battery box.

Cleaning and maintenance

Uninstall air filter and air filter cover

Pull the air filter cover toward yourself to remove air filter and air filter cover.

- WARNING:**
1. Before moving, cleaning and perform user maintenance, switch off the appliance, unplug and wait it cool.
 2. Please do not turn on the appliance after the air filter cover removed.

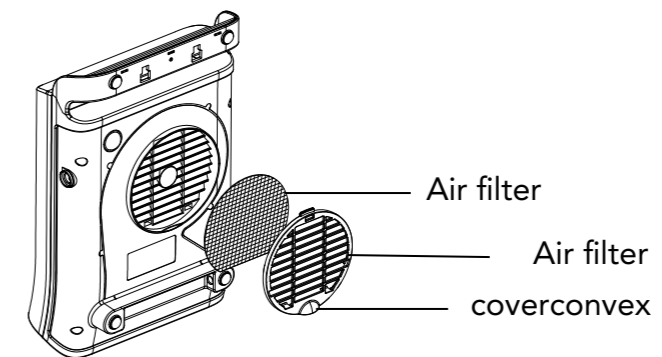

Air filter and air filter cover cleaning method

- Always unplug the unit before moving or servicing. Unplug the unit and wait until the appliance stop running and cool it down before cleaning.
- If there are stains on the surface of product, scrubbing it by using a damp cloth with neutral detergent.
- Do not immerse the power cord, plug and the whole unit into water or rinse under the tap.
- Do not use metal brush, gasoline, benzene, thinner, vinegar, volatile, poisonous or

corrosive detergent to clean the unit to avoid damage of the appliance.

- Please rinse the air filter with water, air filter and cover must be dry up before install.
- After cleaning, appliance must be dried up before use.
- If the appliance will not be used for a long time, store it in the cool, dry and safety place.



How to use

Insert the plug into a 220-240V~50Hz electrical power supply outlet. Press the [main power switch] of back of appliance to “ | ” for turning on the main power, you can hear “Bi Bi” sound, press the on/off  key on control panel start to use appliance.

Turn on/off



Press  to turn on/off appliance. Default setting is low heating, the corresponding red indicator light up.

Heat high/low Button



Press , appliance starts to work on low heating mode, corresponding red indicator light up. Press  again, it is work on high heating mode, corresponding red indicator light up.

NOTED: For heater mode, after turn off the appliance, it will keep running approximate 10 seconds to lower the temperature of the internal parts.

Fan/ heater mode

Press , this appliance under Fan mode function. Press  again, the appliance under heater mode function. Fan mode indicator light is blue color, while heater mode indicator light is red color.

Timer setting

Press  to set timer (1, 2, 4, 8 hours). Press , the corresponding red indicator will light up. When press 4 times, indicator will dim.

Trouble-shooting guide:

Noted: Disassemble or repair appliance should by professionals

	Phenomenon	Reason	Process
①	Heater function not work	Power failure or unplug	Check the circuit or Check the circuit or
②	No hot wind blow out (Good condition of Function button and indicator)	Obstruction at the air outlet	Remove obstructions
③	Air volume has shrunk	The Filter may clogging	Clean the filter
④	Fan function not work (Good condition of Function button and indicator)	The Filter clogging seriously	Clean the filter
⑤	Remote control not work	The battery insulation film is not remove before operation	To remove battery insulation film before operation
		The power of battery may run out	Please replace new battery
⑥	Others	Unidentified reason	Please contact with Shun Hing Electric Service Centre Limited

SPECIFICATION

Model	RA-BH205FW/RA-BH205FY
Color	White / Grey
Rated voltage	220-240V~
Rated frequency	50Hz
Rated power	2050W
Dimension (W x D x H)	240 x 127 x 383 mm
Net weight	2.2 KG

SPECIAL AVOWAL

1. The information above has been checked. Our company reserves the hermeneutic power to any printing errors or misunderstanding on the content.
2. If there are technical improvements on the appliance, the operation manual will be updated without any prior notice. The product appearance and color are subject to the actual appliance.
3. The e-copy of user manual can be sent by e-mail on requested, please call Shun Hing Electric Works & Engineering Co. Ltd. hotline at 2861 2767.

AFTER SALES SERVICES

For any defect, in the judgment of technician from Shun Hing Electric Service Centre Limited, caused under normal use, we are responsible for repairing or replacing parts of the said electrical appliance free of charge within one year guarantee period commencing from the date of purchase. Any defective part which has been replaced shall become our property. Guarantee service does not cover the repair or replacement of accessories, power cord or cabinet, etc. Additional charges shall be levied if services are required.

Please present the official invoice and the guarantee certificate with the sales point's chop or the redemption center's chop for free maintenance. For enquiries, please call Shun Hing Electric Service Centre Limited hotline at 2406 5666.

Free guarantee service will not be provided to the appliance if: 1) it has been explicitly or implicitly modified, tampered with, altered or repaired in any way by persons other than technicians of the Company. Or 2) it has been damaged through misuse, negligence, liquid ingress or corrosion, power interruption, natural calamities or accident or external factors. Or 3) it is not a fixed installation on land. Or 4) the normal operation of the appliance is affected by improper installation. Or 5) the domestic model of appliance is used for industrial or commercial purpose. Or 6) the change of location or ownership of the appliance and did not inform Shun Hing Electric Service Centre Limited.

Rasonic 樂信牌

信興電工工程有限公司

SHUN HING ELECTRIC WORKS & ENGINEERING CO., LTD

辦公室: 香港九龍尖沙咀東部麼地街67號半島中心9樓

OFFICE: 9/F, PENINSULA CENTRE, 67 MODY ROAD, TSIMSHATSUI EAST, KOWLOON, HONG KONG

電話 TEL: (852) 2861 2767

傳真 FAX: (852) 2865 6706

網址 WEBSITE: www.rasonic.com

電郵 EMAIL: shew@shunhinggroup.com

保養及維修 MAINTENANCE AND REPAIR SERVICE

信興電器服務中心有限公司

SHUN HING ELECTRIC SERVICE CENTRE LTD.

辦公室: 香港新界葵涌勝耀街2號信興中心11樓

OFFICE: 11TH FLOOR, SHUN HING CENTRE, 2 SHING YIU STREET, KWAI CHUNG, NEW TERRITORIES, HONG KONG

電話 TEL: (852) 2406 5666

傳真 FAX: (852) 2408 0316

網址 WEBSITE: www.shesc.com

消耗品/附件銷售熱線 CONSUMABLES/ ACCESSORIES SALES HOTLINE

電話 TEL: (852) 2406 5666

客戶服務中心 CUSTOMER SERVICE CENTRES

香港新界葵涌勝耀街2號信興中心1樓

1ST FLOOR, SHUN HING CENTRE, 2 SHING YIU STREET, KWAI CHUNG, NEW TERRITORIES, HONG KONG

電話 TEL: (852) 2406 5439

傳真 FAX: (852) 2408 1389

澳門慕拉士大馬路193-199號南嶺工業大廈5樓I座

AVENIDA DE VENCESLAU DE MORAIS, NO. 193-199, 5 ANDAR-I, EDF. INDUSTRIAL NAM LENG, MACAU

電話 TEL: (853) 2836 2928

傳真 FAX: (853) 2833 6405

有關最新之客戶服務中心資訊, 請參閱信興服務中心網址 www.shesc.com 或致電維修服務熱線查詢。

For the latest information of customer service centres, please visit www.shesc.com or call us at our hotline.

