

Rasonic

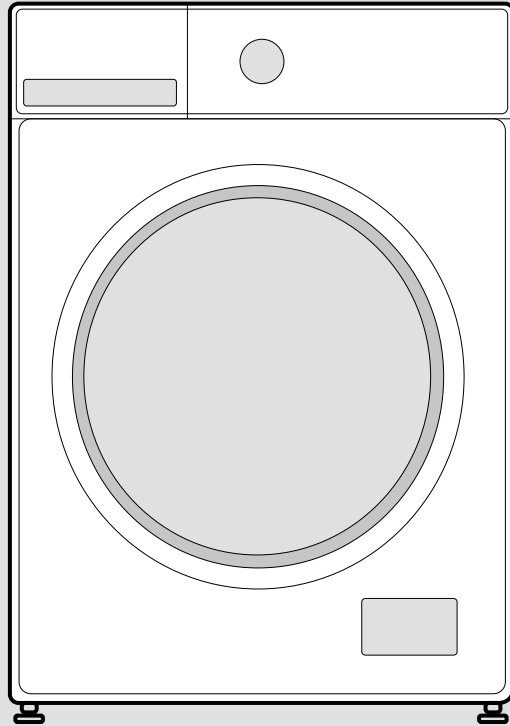

Washing Machine

USER MANUAL

RW-UA814F

Read all instructions and explanations for installation before use.
Follow the instructions carefully. Keep the user manual for future reference.
The images in the user manual may not match with the real object and are reference only.

CONTENTS

SAFETY INSTRUCTIONS	02
SPECIFICATIONS	06
PRODUCT OVERVIEW	07
QUICK START GUIDE	08
PRODUCT INSTALLATION	11
OPERATION INSTRUCTIONS	15
CLEANING AND MAINTENANCE	26
TROUBLE SHOOTING	30
DISPOSAL AND RECYCLING	31

SAFETY INSTRUCTIONS

Safety Instructions

Please read the following safety information thoroughly and follow it strictly to minimize the risk of fire or explosion, electric shock and to prevent property damage, personal injury or loss of life. Failing to follow these instructions shall void any warranty.

- Children should be supervised that they do not play with the appliance.
- If the supply cord is damaged, it must be replaced by the manufacturer, its service agent or similarly qualified persons in order to avoid a hazard.
- Max. Inlet water pressure 1 MPa. Min. inlet water pressure 0.05 MPa.
- The new hose-sets supplied with the appliance are to be used and that old hose-sets should not be reused.
- This appliance is intended to be used in household and similar applications such as:
 - Staff kitchen areas in shops, offices and other working environments;
 - Farm houses;
 - By clients in hotels, motels and other residential type environments;
 - Bed and breakfast type environments;
- Do not install the machine on a carpet floor.
- Carpet does not obstruct the opening for washing machine with ventilation opening in the base.

Model	Washing Capacity
RW-UA814F	8.0kg

- The appliance is not to be used by persons (including children) with reduced physical, sensory or mental capabilities, or lack of experience and knowledge, unless they have been given supervision or instruction.
- Children being supervised not to play with the appliance.

For use :

- This appliance can be used by children aged from 8 years and above and persons with reduced physical, sensory or mental capabilities or lack of experience and knowledge if they have been given supervision or instruction concerning use of the appliance in a safe way and understand the hazards involved.
- Children does not play with the appliance.
- Cleaning and user maintenance are not made by children without supervision.
- Children of less than 3 years are kept away unless continuously supervised.
- The product is intended only for home use and for textiles in household amounts suitable for machine washing.
- This appliance is for indoor use only and not intended for built in use. Only use according to these instructions. The appliance is not intended for commercial use.
- Any other use is considered as improper use. The producer is not responsible for any damage or injuries that may result of it.

Explanation of Symbols



DANGER

This symbol indicates that there are dangers to the life and health of persons due to extremely flammable gas.



WARNING OF ELECTRICAL VOLTAGE

This symbol indicates that there is a danger to life and health of persons due to voltage.



WARNING

The signal word indicates a hazard with a medium level of risk which, if not avoided, may result in death or serious injury.



CAUTION

The signal word indicates a hazard with a low degree of risk which, if not avoided, may result in minor or moderate injury.



NOTE

The signal word indicates important information (e.g. damage to property), but not danger.



OBSERVE INSTRUCTIONS

This symbol indicates that a service technician should only operate and maintain this appliance in accordance with the operating instructions.

⚠ WARNING: Electric Shock Hazard

- If the machine is damaged, it must not be operated unless repaired by the manufacturer, its service agent or similarly qualified persons.
- Risk of electric shock!
- Animals and children may climb into the machine. Check the machine before every operation.
- Do not climb or sit on the appliance.

Installation Location and Surrounding

- All washing and additional substances are to be kept in a safe place out of the reach of children.
- Keep the appliance clear from heating sources and direct sunlight to avoid plastic and rubber parts to corrode.
- Do not use the appliance in humid environments or rooms containing explosive or caustic gas. In case of water leakage or water splashes, let the appliance dry in the open air.
- The appliance must not be installed behind a lockable door, a sliding door or a door with a hinge on the opposite side to that of the machine .
- Do not operate the machine in rooms with a temperature of below 5°C. This can cause damages to parts of it. If it is unavoidable, make sure to drain the water completely from the appliance after every use (see“Maintenance - Cleaning of drain pump filter”) to avoid damages caused by frost.
- Never use flammable sprays or substances in the immediate proximity of the appliance.

Installation

- Remove all packaging material and transport bolts before using the appliance. Otherwise, serious damage may result.
- This appliance is equipped with a single inlet valve and can be connected to the cold water supply only.
- Mains plug must be accessible after installation.
- Before washing clothes for the first time, the product shall be operated once throughout all the procedures without any clothes inside.
- Do not put any excessively heavy objects on the appliance, like water containers or heating devices.

Electrical Connection

- Make sure the supply cable is not trapped by the machine, or it can get damaged.
- Connect the product to a grounded outlet protected by a fuse complying with the values in the “Technical specifications” table. The grounding installation has to be made by a qualified electrician. Ensure that the machine is installed in accordance with the local regulations.
- Water and electrical connections must be carried out by a qualified technician in accordance with the manufacturer’s instructions and local safety regulations.



WARNING:

- Do not use multiple plugs or extension cords.
- The appliance must not have an external switching device such as a timer or connected to a circuit that is regularly switched on and off.
- Do not pull the plug out of the mains outlet if there is flammable gas around.
- Never pull out power plug with wet hands.
- Always pull at the plug, not at the cable.
- Always unplug the appliance if it is not being used.

Water Connections

- Check the connections of the water inlet tubes, the water tap and the outlet hose for possible problems due to changes of water pressure. If the connections loosen or leak, close the water tap and get it repaired.
- Do not use the appliance before the pipes and hoses are installed properly by qualified persons.
- Glass door may become very hot during the operation. Keep children and pets far away from the machine while it is operating.
- The water inlet and outlet hoses have to be safely installed and remain undamaged.
- Otherwise, water leakage can occur.
- Do not remove the drain pump filter while there is still water in the appliance. Big quantities of water can leak out, and there is a risk of scalding due to hot water.

Operation and Maintenance

- Never use any flammable, explosive or toxic solvents. Do not use gasoline and alcohol etc. as detergents. Only select detergents that are suitable for machine washing.
- Make sure that all pockets are emptied. Sharp and rigid items such as coins, brooches, nails, screws, stones etc. may cause serious damages to this machine.
- Remove all objects from pockets such as lighters and matches before use the appliance. Thoroughly rinse items that have been washed by hand.
- Items that have been soiled with substances such as cooking oil, acetone, alcohol, petrol, kerosene, spot removers, turpentine, wax and wax removers should be washed in hot with an extra amount of detergent before being dried in the appliance.
- Items containing foam rubber (latex foam), shower caps, water proof textiles, rubber backed articles and clothes or pillows fitted with foam rubber pads should not be washed in the machine.
- Fabric softeners or similar products should be used as recommended in their instructions.
- Never try to open the door forcefully.
- The door will unlock shortly after the end of a cycle.
- Please do not close the door with excessive force. If it is found difficult to close the door, please check if the clothes are properly inserted and distributed.
- Always unplug the appliance and close the water tap before cleaning and maintenance and after each use.
- Never pour water over the appliance for cleaning purpose. Risk of electric shock!
- Repairs shall only be carried out by the manufacturer, its service agent or similarly qualified persons in order to avoid a hazard.
- The producer will not be responsible for damages caused by the intervention of not authorized persons.

Transport

- Before Transport:
 - Bolts shall be reinstalled to the machine by a specialized person;
 - Accumulated water shall be drained out of the machine.
- This appliance is heavy. Transport with care. Never hold any protruding part of the machine when lifting. The machine door can not be used as a handle.

SPECIFICATIONS

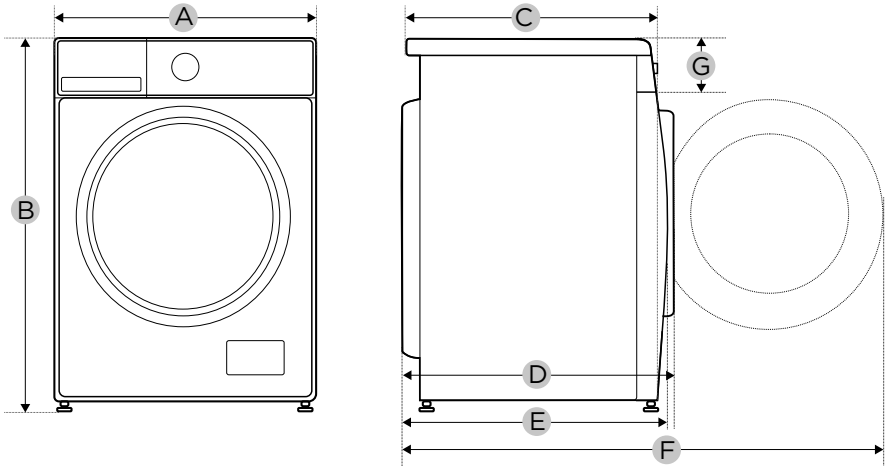

Model	RW-UA814F
Power Supply	220-240V~,50Hz
MAX. Current	10A
Standard Water Pressure	0.05MPa-1MPa
Washing Capacity	8.0kg
Dimension	
A	595mm
B	850mm
C	475mm
Weight	63kg
Rated Power	1880W
Reference Dimension	
D	540mm
E	525mm
F	985mm
G	135mm

PRODUCT OVERVIEW

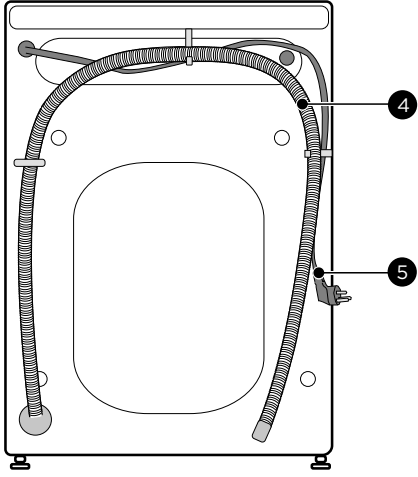
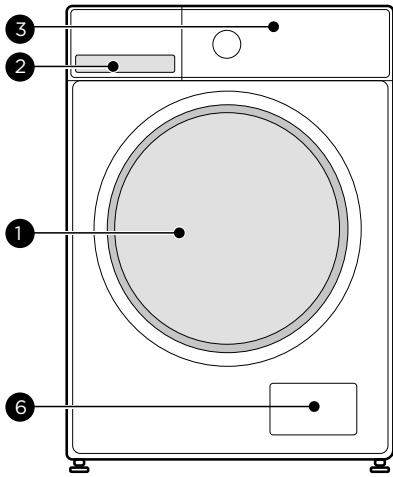

1	Door
2	Detergent dispenser
3	Control panel

4	Drain hose
5	Power supply cord
6	Drain pump filter

NOTE

The product picture is for illustration only, refer to real product as reference.

Accessories

4 x Cover caps

1 x Supply hose cold water

1 x User manual

Soundproof Sponge

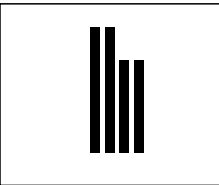
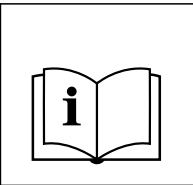
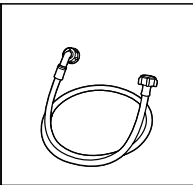
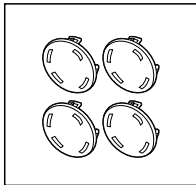

QUICK START GUIDE



CAUTION

- Before washing, please make sure the machine is installed properly.
- Your appliance was thoroughly checked before it left the factory. To remove any residual water and to neutralize potential odors, it's recommended to clean your appliance before first use. For this reason, recommended to clean the inner drum by running the "DRUM CLEAN" or other program with the optional temperature of 90°C. Be careful not to put laundry and detergent in the machine.

1. Before Washing

1. Plug in

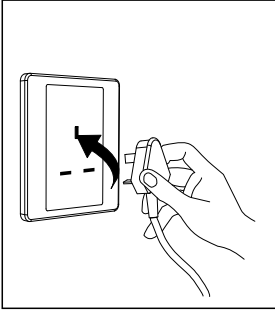

2. Open tap

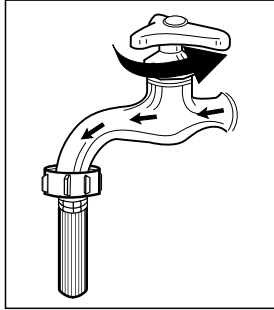

3. Load

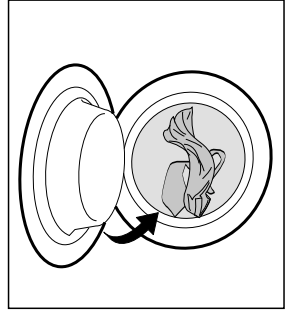

4. Close door

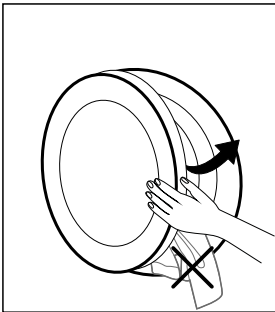

5. Add detergent

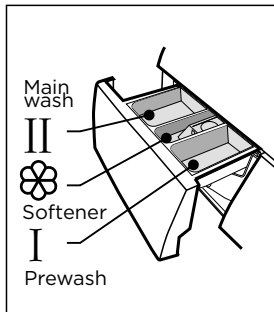

NOTE

- Detergent need to be added in compartment I if the pre-wash function is selected.
- When closing the door, please make sure that your clothes are not caught between the sealing ring and the machine door to prevent water leakage caused by pulling and damaging the sealing ring during operation.

2. Washing

1. Select programme

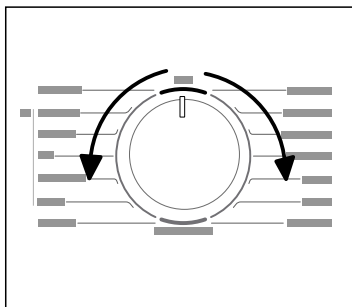

2. Select function or remain default settings

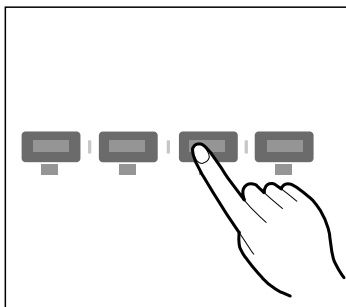

3. Press Start/Pause to start the program

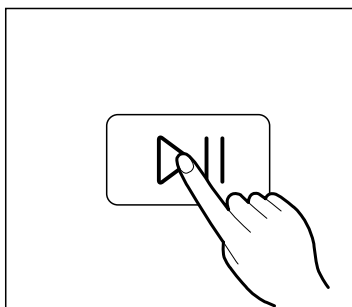

NOTE

1 : If default is selected, step 2 can be skipped.

2: The function button line chart is for reference only, please refer to real product as standard.

3. After Washing

Buzzer beep and “End” on display.

PRODUCT INSTALLATION

Installation Area

WARNING

- Stability is important to prevent the product from wandering!
- Make sure the machine is standing leveled and stable.
- Make sure that the product does not stand onto the power cord.
- Make sure to maintain the minimum distances from the walls as shown in the picture.

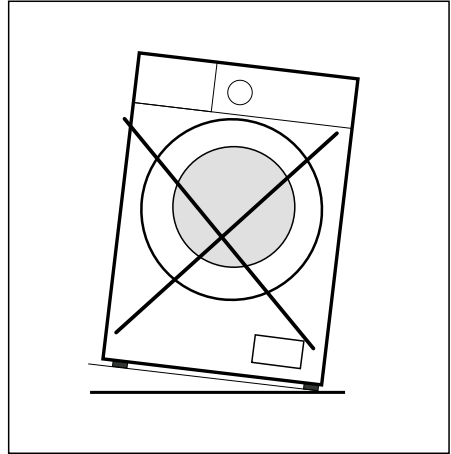
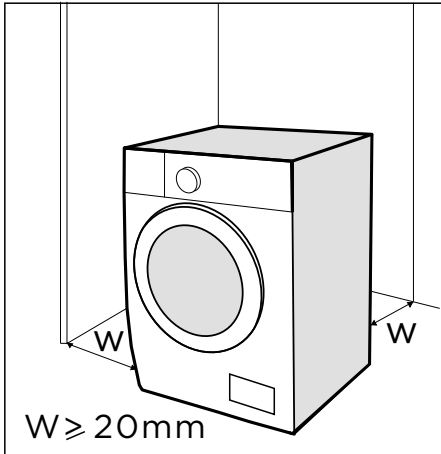

Before installing the machine, the location characterized as follows shall be selected:

1. Rigid, dry, and level surface.
2. Avoid direct sunlight.
3. Sufficient ventilation.
4. Room temperature is above 5 °C .
5. Keep far away from the heat sources such as coal or gas burning appliances.

Unpacking/Packing the Machine

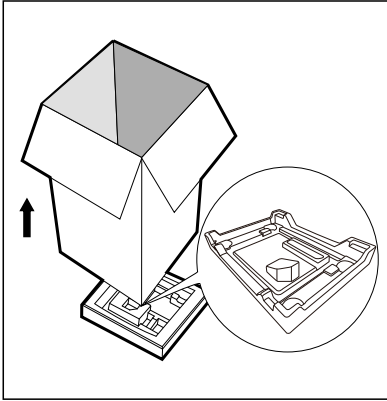

⚠ WARNING

- Packaging material (e.g. Films, Styrofoam) can be dangerous for children.
- There is a risk of suffocation ! Keep all packaging well away from children.

1. Remove the cardboard box and styrofoam packing.
2. Lift the machine and remove the base packaging.
3. Remove the tape securing the power supply cord and drain hose.
4. Remove the inlet hose from the drum.

The process of packing the machine is just the reverse of unpacking above.

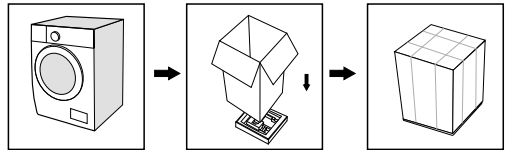

Remove Transport Bolts

⚠ WARNING

You must remove the transport bolts from the backside before using the product.

1. Loosen the 4 transport bolts with a spanner.

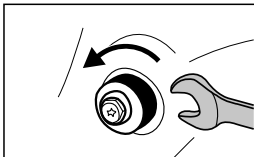

2. Remove the bolts including the rubber parts and keep them for future use.

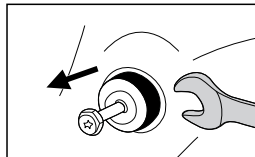

3. Close the holes using the cover caps.

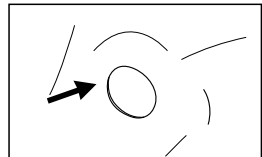

Levelling the Machine

WARNING

The lock nuts on all four feet must be screwed tightly against the housing.

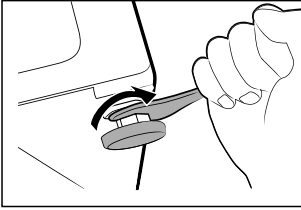

1. Loosen the lock nut.
2. Turn the foot until it reaches the floor.
3. Adjust the legs and lock the nuts with a spanner.
Make sure the machine is level using a spirit level.

Connect the Water Supply Hose

WARNING

To prevent leakage or water damage, follow the instructions in this chapter.

- Do not kink, crush or modify water inlet hose.

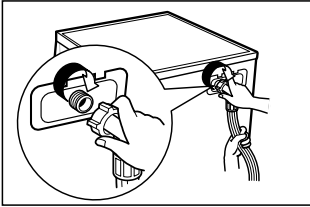

Connect the water supply hose to the water inlet valve and a water tap with cold water as indicated.

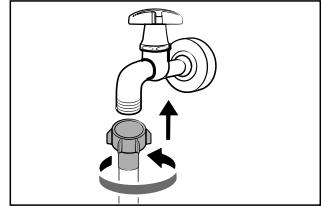

NOTE

- Connect manually, do not use tools. Check if the connections are tight.

Drain Hose

WARNING

- Do not kink or protract the drain hose.
- Position drain hose properly ,otherwise damage might result in water leakage.
- It is not allowed to remove the buckle of drain pipe.

There are two ways to place the end of drain hose:

1. Put it into the water trough.

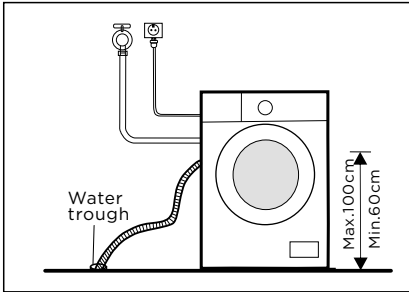

2. Connect it to the branch drain pipe of the trough.

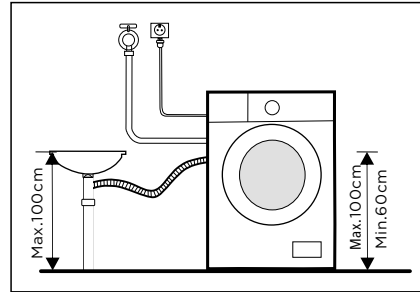

Soundproof Sponge

NOTE

- Please make sure to assemble the Soundproof Sponge, which can effectively reduce the noise caused by the machine while working, in order to provide you with a more peaceful and quiet living environment.

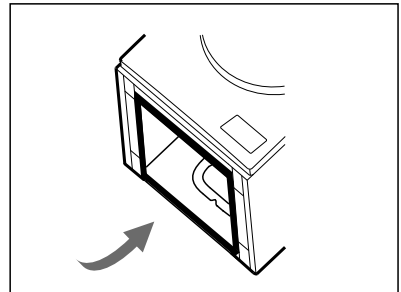
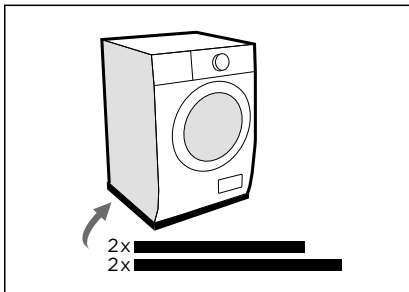

1. Get the machine laid on the floor, using some soft material like foam or clothes between the machine and floor for a protection;
2. Stick the 2x longer sponges to the longer bottom edges of machine, and the 2x shorter sponges to the shorter bottom edges.

OPERATION INSTRUCTIONS

Before Each Washing

- The ambient temperature of the machine should be 5°C-40°C. If used under 0°C, the inlet valve and draining system may be damaged. If the machine is installed under freezing conditions, it should be transferred to normal ambient temperature to ensure the water supply hose and drain hose can unfreeze before use.
- Please check your laundry care labels and the detergent use instructions before wash. Use non-foaming or less-foaming detergent suitable for machine properly.

1. Take all items out of the pockets

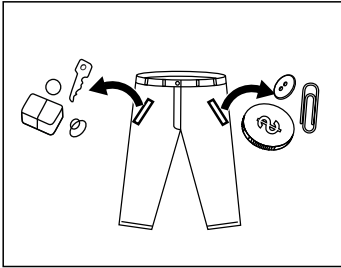

2. Sort laundry according to color and textile type

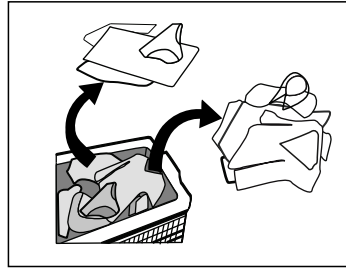

3. Tie together long textile strips and belts, close zips and button

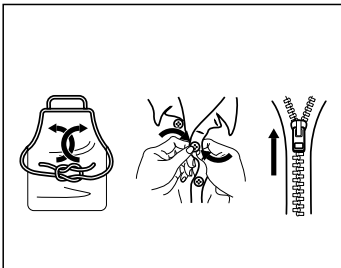

4. Put small items into a laundry bag

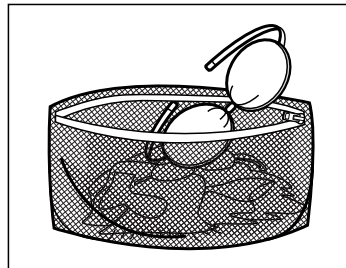

WARNING

- Do not wash or dry articles that have been cleaned in, washed in, soaked in, or dabbed with combustible or explosive substances like wax, oil, paint, gasoline, alcohol, kerosene and other flammable materials.
- Washing single clothes items may easily create big eccentricity. Therefore it is suggested to add one or two more laundry items to the wash so that spin can be done smoothly.
- Do not wash, spin water-proof seats, mats or clothing.

Detergent Dispenser

- I Pre wash
- II Main wash
- ☼ Softener
- ☉ Release button to pull out the dispenser

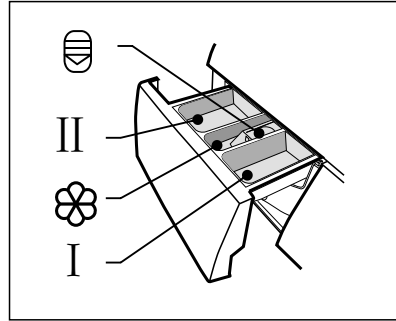

⚠ CAUTION

- Detergent only need to be added in “compartment I ”after selecting pre-wash function.

Programme	I	II / ☉	☼	Programme	I	II / ☉	☼
QUICK 15'		●	○	DRUM CLEAN			
SYNTHETIC	○	●	○	SPORTS	○	●	○
20°C	○	●	○	JEANS	○	●	○
ECO 40-60		●	○	BABY CARE	○	●	○
WOOL		●	○	MIX	○	●	○
DUVET		●	○	COTTON	○	●	○
SPIN ONLY				RAPID 59'		●	○

● Means must ○ Means optional

Detergent Recommendation

Recommended washing detergent	Type of laundry and textile	Programme	Washing temp. °C
Heavy-duty detergent with bleaching agents and optical brighteners	White laundry made from boil-proof cotton or linen	COTTON	40/60
Colour detergent without bleaching agent and optical brighteners	Coloured laundry made from cotton or linen	COTTON	20/40
Color or mild detergent without optical brighteners	Coloured laundry made from easy care fibres or synthetic materials	COTTON, SYNTHETIC	20/40
Mild washing detergent	Delicate textiles, silk, viscose	SYNTHETIC	20
Special wool detergent	Wool	WOOL	20/40

NOTE

- Agglomerating or ropy detergent or additive can be diluted in some water before pouring it into the detergent dispenser, to avoid its inlet to get blocked and thus cause a water overflow.
- Please choose the suitable type of detergent to get a maximum of washing performance and a minimum of water and energy consumption.
- To achieve the best cleaning result a proper detergent dosing is important.
- Use a reduced detergent amount if the drum is not filled completely.
- Always adjust the amount of detergent to the water hardness, if your tap water is soft, use less detergent.
- Dose according to how dirty your laundry is, less dirty clothes require less detergent.
- Highly concentrated (compact detergent) requires particularly accurate dosing.

Following symptoms are a sign of detergent overdosing:

- heavy foam formation
- poor washing and rinsing result

Following symptoms are a sign of detergent under dosing:

- laundry turns grey
- built-up of lime scale deposits on the drum, the heating element and/or the laundry

- Detergent should be used according to the instruction of the detergent manufacturer and selected according to type, color, soiling of the fabric and the washing temperature.
- If too many suds occur, reduce the detergent amount.
- If too much detergent is used, too many suds can occur and this will result in poor washing results or cause heavy load to the motor.

Control Panel

Model:RW-UA814F

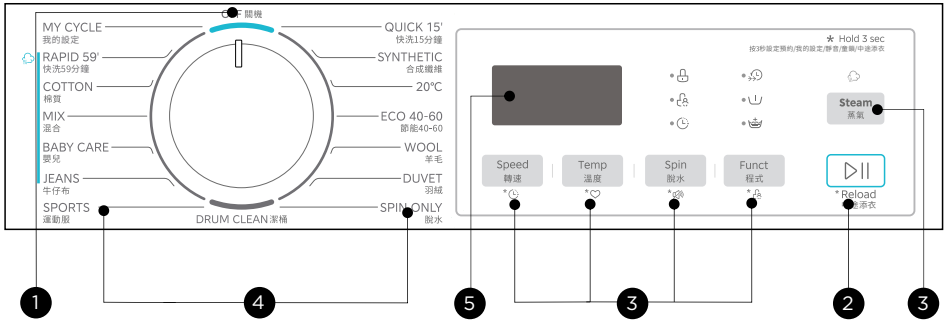

1 OFF

Turn the appliance off.

2 Start/Pause

Start or pause your programme.

3 Option

This allows you to select additional functions.

4 Programmes

Available according to the laundry type.

5 Display

The display shows settings, estimated remaining time, options and status messages.

NOTE

- The Panel is reference only, please refer to real product as standard.

Display

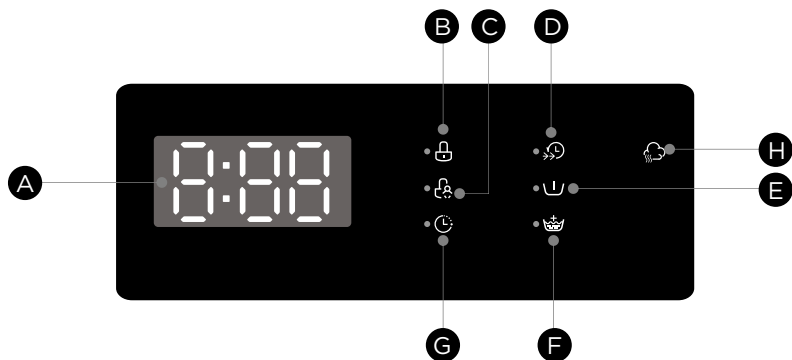

A Display

Wash Time
125
Speed
400
End
End

Delay Time
2H
Error
E30
Temp
30

B Door Lock

C Child Lock

D Speed wash

E Pre Wash

F Extra Rinse

G Delay

H Steam

Programmes

Model:RW-UA814F

Programme	Load (kg)	Default Time (h:min)
	8.0	
QUICK 15'	2.0	0:15
SYNTHETIC	4.0	3:18
20°C	4.0	1:08
ECO 40-60	8.0	3:38
WOOL	2.0	0:59
DUVET	2.5	1:27
SPIN ONLY	8.0	0:12
DRUM CLEAN	--	1:18
SPORTS	4.0	0:47
JEANS	8.0	1:35
BABY CARE	8.0	2:01
MIX	8.0	1:20
COTTON	8.0	1:28
RAPID 59'	4.0	0:59

NOTE

- The parameters in this table are only for user's reference. The actual parameters maybe different with the parameters in above mentioned table.











































Programmes are available according to the laundry type.

Programmes	
COTTON	Hard-wearing textiles, heat-resistant textiles made of cotton or linen.
QUICK 15'	Extra short programme approx, suitable for lightly soiled washing as a small amounts of laundry.
SYNTHETIC	Wash synthetic articles, for example: shirts, coats, blending. While washing the knitting textiles, detergent quantity shall be reduced due to its loose string construction and easily forming bubbles.
RAPID 59'	Designed to help you clean clothes, save time, and optimize your laundry routine efficiently.
JEANS	Specially for jeans.
MIX	Mixed load consisting of textiles made of cotton and synthetics.
20°C	Able to clean lightly soiled cotton laundry, at a nominal temperature of 20 °C.
BABY CARE	Washing the baby's clothes, it can make the baby's wear cleaner and make the rinse performance better to protect the baby skin.
DUVET	Compared to the cotton, it uses a gentle drum rotation and a higher water level to better protect the down material.
WOOL	Hand or machine-washable wool or richwool textiles. Especially gentle wash programme to prevent shrinkage, longer programme pauses (textiles rest in wash liquor).
SPIN ONLY	Spins and drains the water.
ECO 40-60	Able to clean normally soiled cotton laundry declared to be washable at 40 °C or 60 °C, together in the same cycle.
DRUM CLEAN	Specially set in this machine to clean the drum and tube. It applies 90 °C high temperature sterilization to make the clothes washing more green. The customer can use this programme regularly according to the need.
SPORTS	Washing the activewear.

NOTE

- Reference only , please refer to real product as standard.

Option

Cycle	Default Temp.(°C)	Default spin speed (rpm)	Additional functions
		1400 (Display 14-)	
QUICK 15'	Cold	800 (Display 800)	 ,  ,
SYNTHETIC	40	1200 (Display 12-)	 ,  ,  ,  ,
20°C	20	1000 (Display 10-)	 ,  ,  ,
ECO 40-60	--	--	 ,
WOOL	Cold	600 (Display 600)	 ,  ,
DUVET	40	800 (Display 800)	 ,  ,
SPIN ONLY	--	1000 (Display 10-)	 ,
DRUM CLEAN	90	--	 ,
SPORTS	20	800 (Display 800)	 ,  , 
JEANS	30	800 (Display 800)	 ,  ,  ,  , 
BABY CARE	60	1000 (Display 10-)	 ,  ,  ,  , 
MIX	40	1000 (Display 10-)	 ,  ,  ,  , 
COTTON	40	1000 (Display 10-)	 ,  ,  ,  , 
RAPID 59'	30	1000 (Display 10-)	 ,  ,  , 

NOTE

- The table shows which cycle offers which options for adjustment.

Spin
脱水

Spin

When needed, the spinning speed can be adjusted pressing the Spin button in the following steps: 0-400-600-800-1000-1200-1400

Delay
預約

Delay

1. Select a programme.
2. Press the "Speed" button for 3 seconds to choose the delaying time 0-24H.
3. Press [Start/Pause] to start the delay operation.



Choose programme

Setting time

Start

To cancel the Delay function, press the "Speed" button for 3 seconds before starting the program until the display shows 0 H. If the program has already started, switch the appliance off and afterwards on and select a new programme.

Pre Wash

Pre Wash

Extra washing function before the main washing cycle starts to increase the washing performance.

Note: Detergent needs to be added to the compartment I.

Extra Rinse

Extra Rinse

The laundry will undergo an extra rinse after selecting this function.

Speed
轉速

Speed (Speed Wash)

Pressing the "speed" button will shorten the washing time. After pressing the button, the "↻" icon will light up. To cancel, press it again. This function is only available for Synthetic, Jeans, Baby Care, Mix, Cotton and Rapid 59'.

Temp
溫度

Temp

When needed, the washing temperature can be adjusted by pressing the temperature button in the following steps: Cold -20°C-30°C - 40°C- 60°C - 90°C.

MY CYCLE

MY CYCLE

To memory the frequently used programme.

After choosing the programme and setting the options, press [Temp] button for 3 seconds before start to wash.

The default setting course is Cotton.



Child Lock

To avoid mis operation by children.



Press [Func.] for 3 seconds until the buzzer beep.
The child lock indicator switches on.



CAUTION

When the Child Lock is activated, the display will alternately show “CL” and the remaining time.

Pressing any other button will cause the Child Lock indicator to flash.

When the program ends, “CL” and “End” will alternate on the display.

The Child Lock deactivates all functions in control panel except the Child lock button and OFF function!

After turning off the appliance, the child lock will not be automatically released.

Only pressing of the button can deactivate the Child Lock!

Please deactivate the Child Lock before selecting a new program!



Mute the buzzer



Choose the Program



*

Press the [Spin] button for 3 seconds,
the buzzer is mute.

To act the buzzer function, press the button again for 3 seconds. The setting will be kept until the next reset.



CAUTION

- After Muting the buzzer function, the sounds will not be activated any more.
-



Steam

Steam can be used with the Rapid 59', Cotton, Mix, Baby Care, and Jeans.
It uses steam to eliminate bacteria and remove odors.





Reload

This operation can be executed during the washing progress.

When the drum is still rolling and there is large amount of water with high temperature in the drum.

The state is unsafe and the door cannot be opened forcefully.

To press [] for 3 sec. to reload, and start the clothes adding in the midway function. Please follow the steps as below:

1. Wait until the drum stops rotation.
2. The door lock is unlocked.
3. Close the door when the clothes are reloaded and press the [] button.



CAUTION

- Donot use the Reload function when the water level over the edge of the inner tub or the temperature is higher.

CLEANING AND MAINTENANCE

Cleaning and Care

WARNING

- Always unplug the appliance and close the water tap before cleaning and maintenance.
- When cleaning the product, do not stretch your hands, feet or arms into the bottom of the machine case to prevent scratches.

Cleaning the Cabinet

Proper maintenance on the machine can extend its working life. The surface can be cleaned with diluted non-abrasive neutral detergents when necessary. If there is any water overflow, use a towel to wipe it off immediately. Never use sharp items to clean the appliance.

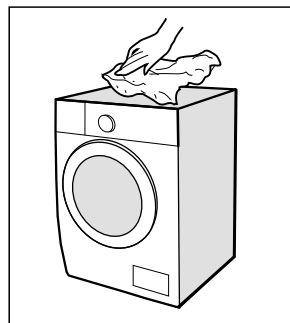

CAUTION

- Never use abrasive or caustic agents. Such as formic acids or its diluted solvents or similar substances, like alcohol or chemical products.

Cleaning the Drum

Any rust stains left inside the drum by metal articles must be removed immediately using chlorine-free detergents. Never use steel wool for cleaning the drum!

NOTE

- Keep any laundry away from the machine while cleaning the drum.

Cleaning the Door Seal and Glass

Wipe the glass and seal after each wash to remove lint and stains. If lint builds up it can cause leakages.

Remove any coins, buttons and other objects from the seal after each wash.

Clean the door seal and glass every month to ensure the normal operation of the appliance.

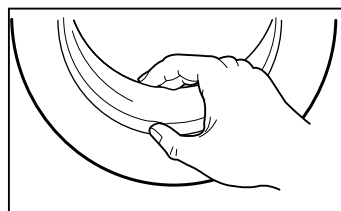

Cleaning the Inlet Filter

NOTE

- Diminishing water flow is a sign that the filter needs to be cleaned.

1. Close the tap and remove the water supply hose from it.

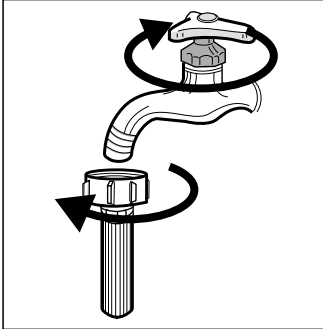

2. Clean the filter with a brush.

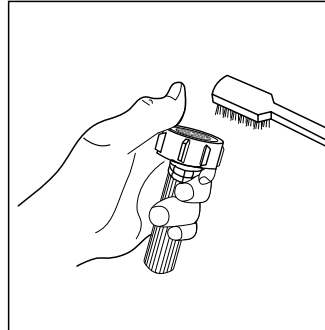

3. Unscrew the water supply hose from the backside of the machine. Pull out the filter with long nose pliers.

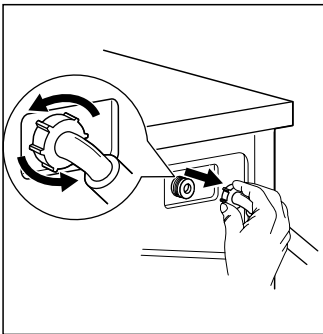

4. Use a brush to clean the filter.

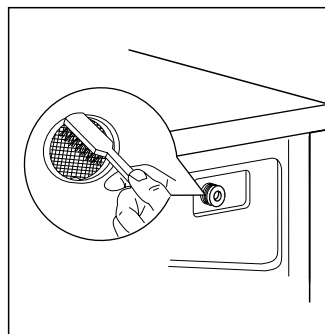

5. Reinstall the filter to the water inlet and reconnect the water supply hose.
6. Clean the inlet filter every 3 months to ensure the normal operation of the appliance.

Cleaning the Detergent Dispenser

- Press down the release [] on the softener cover and pull the dispenser drawer out of the recess.
- Lift the softener cover off the dispenser drawer and wash both items with water.
- Clean the inside of the recess with a brush.
- Restore the softener cover and push the drawer back into the recess.

1. Press the release and remove the dispenser drawer

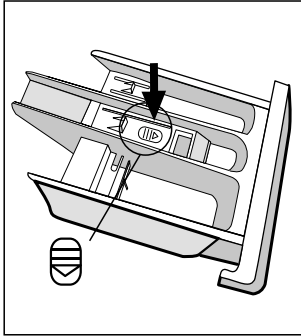

2. Clean the dispenser drawer and the softener cover under water

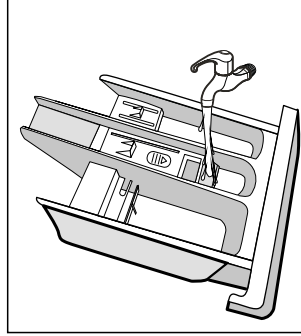

3. Clean the recess with a soft brush

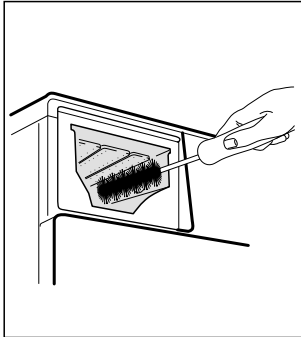

4. Insert the dispenser drawer

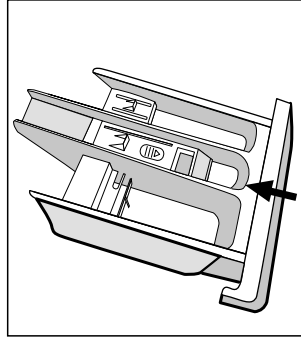

NOTE

- Do not use abrasive or caustic agents to clean plastic parts.
- Clean the detergent dispenser every 3 months to ensure the normal operation of the appliance.

Cleaning the Drain Pump Filter

WARNING

- Make sure that the machine has finished the washing cycle and is empty. Switch it off and unplug it before cleaning the drain pump filter.
- Be careful of hot water. Wait for water cooling down. Risk of scalding!
- Clean the filter periodically every 3 months to ensure the normal operation of the appliance.

1. Open the lower cover cap

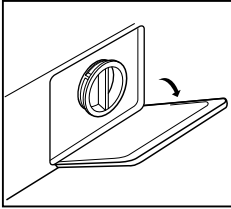

2. Rotate 90°C and pull out the emergency drain hose, and take off the hose cap

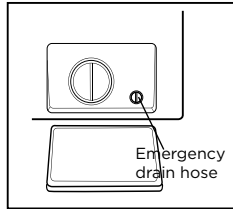

3. After water runs out, reset the drain hose

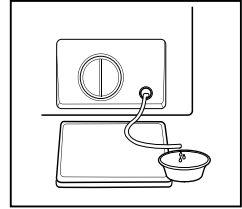

4. Open the filter by turning to the counter clockwise

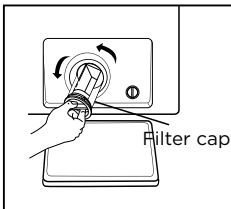

5. Remove extraneous matters

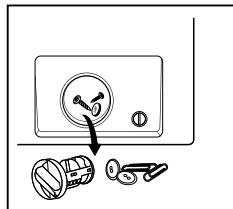

6. Carefully reinsert the filter and screw the lower cover cap in clockwise

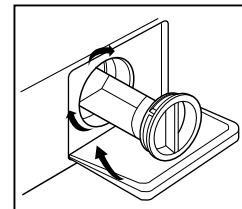

CAUTION

- Make sure that valve cap and emergency drain hose are reinstalled properly, cap plates should be inserted aligning to hole plates otherwise water may leak.
- Some machines don't have emergency drain hose, so step 2 and step 3 can be skipped. Rotate lower cover cap directly to make water run into basin.
- When the appliance is in use and depending on the program selected there can be hot water in the pump. Never remove the pump cover during a wash cycle, always wait until the appliance has finished the cycle, and is empty. When replacing the cover, ensure it is securely re-tightened.

TROUBLE SHOOTING

Whenever there is a problem with the appliance, check if you can solve it following the tables below. If the problem persists, contact the Shun Hing Electric Service Centre Ltd.

Description	Possible Cause	Solution
Appliance does not start	Door is not closed properly. Clothes are stuck.	Close the door properly and restart. Check the laundry.
Door can't be opened	Safety protection is activated.	Disconnect the power and restart.
Water leakage	Connections are not tight enough.	Check and fasten the water inlet pipe. Check and clean the outlet hose.
Detergent residues in the detergent dispenser	Detergent is damp and/or clotted.	Clean and wipe the detergent dispenser dry.
Indicator or display does not work	PC board or harness have connection problems.	Switch off the power and check if the mains plug is connected properly.
Abnormal noise	Fixing bolts are still in place. Floor is not solid or level.	Check if the fixing bolts have been removed. Make sure the appliance is installed on a solid and level floor.

Error Codes

Description	Possible Cause	Solution
E30	Door is not closed properly.	Close the door properly and restart.
E10	Water injecting problem during wash cycle.	Check if the water pressure is high enough. Straighten the water pipe. Clean the inlet valve filter.
E21	Overtime water draining	Check the drain hose for blockage.
E12	Water overflow	Restart the appliance.
EXX	Others	Restart the appliance. If problem persists, please contact the Shun Hing Electric Service Centre Ltd.

DISPOSAL AND RECYCLING

Important Instructions for Environment

From 31 December 2018, the disposal licensing control, import and export permit control and landfill disposal ban in respect of abandoned regulated electrical equipment (REE) have commenced. Any person who is engaged in the storage, treatment, reprocessing or recycling of abandoned REE must obtain a waste disposal license; a permit is required for the import and export of abandoned REE; and abandoned REE is no longer be accepted for disposal at the landfills and other designated waste disposal facilities (e.g. refuse transfer stations).



● SPECIAL AVOWAL

1. The information above has been checked. Our company reserves the hermeneutic power to any printing errors or misunderstanding on the content.
2. If there are technical improvements on the appliance, the User manual will be updated without any prior notice. The product appearance and color are subject to the actual appliance.
3. The e-copy of user manual can be sent by e-mail on requested, please call Shun Hing Electric Works & Engineering Co. Ltd. hotline at 2861 2767.

● AFTER SALES SERVICES

For any defect, in the judgment of technician from Shun Hing Electric Service Centre Limited, caused under normal use, we are responsible for repairing or replacing parts of the said electrical appliance free of charge within one year guarantee period commencing from the date of purchase. Any defective part which has been replaced shall become our property. Guarantee service does not cover the repair or replacement of accessories, power cord or cabinet, etc. Additional charges shall be levied if services are required. Please present the official invoice and the guarantee certificate with the sales point's chop or the redemption center's chop for free maintenance. For enquiries, please call Shun Hing Electric Service Centre Limited hotline at 2406 5666.

Turn off the power and contact Shun Hing Electric Service Centre Ltd. as soon as any of the following events occur.

- The circuit breaker frequently trips or the fuse blows regularly.
- If water or foreign objects have accidentally entered the washing machine.
- If there is abnormal sound during operation.

信興電工工程有限公司

SHUN HING ELECTRIC WORKS & ENGINEERING CO., LTD

辦公室: 香港九龍尖沙咀東部麼地道 67 號半島中心 9 樓

OFFICE: 9/F, PENINSULA CENTRE, 67 MODY ROAD, TSIMSHATSUI EAST,
KOWLOON, HONG KONG

電話 TEL: (852) 2861 2767

傳真 FAX: (852) 2865 6706

網址 WEBSITE: www.shew.com.hk 電郵 EMAIL: shew@shunhinggroup.com

保養及維修 MAINTENANCE AND REPAIR SERVICE

信興電器服務中心有限公司

SHUN HING ELECTRIC SERVICE CENTRE LTD.

辦公室: 香港新界葵涌勝耀街2號信興中心11樓

OFFICE: 11TH FLOOR, SHUN HING CENTRE, 2 SHING YIU STREET, KWAI CHUNG, NEW
TERRITORIES, HONG KONG

電話 TEL: (852) 2406 5666

傳真 FAX: (852) 2408 0316

網址 WEBSITE: www.shesc.com

消耗品/附件銷售熱線 CONSUMABLES/ ACCESSORIES SALES HOTLINE

電話 TEL: (852) 2406 5666

客戶服務中心 CUSTOMER SERVICE CENTRES

香港新界葵涌勝耀街2號信興中心1樓

1ST FLOOR, SHUN HING CENTRE, 2 SHING YIU STREET, KWAI CHUNG, NEW
TERRITORIES, HONG KONG

電話 TEL: (852) 2406 5439

傳真 FAX: (852) 2408 1389

澳門慕拉士大馬路149號激成工業大廈(第一期)2樓F座

Avenida de Venceslau de Morais, No. 149, 2 andar - F, Edif, Industrial Keck
Seng (Bloco 1), Macau

電話 TEL: (853) 2836 2928

傳真 FAX: (853) 2833 6405

有關最新之客戶服務中心資訊, 請參閱信興服務中心網址: www.shesc.com或致電維修服務熱線查詢。

For the latest information of customer service centres, please visit www.shesc.com or call us at our hotline.

