

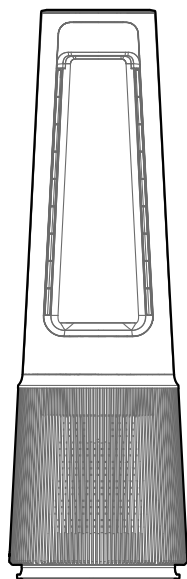

RBF-85AHZ

空氣淨化無葉風扇暖風機



僅供家居使用

使用說明書

- 警告：使用本電器前，請仔細閱讀本說明書並妥善保存以供日後參考。
- 產品若有技術改進，將會編進新版說明書中，恕不另行通知。詳情請諮詢經銷商或製造商。
- 上圖僅供參考。請以實物為準。
- 該電器僅適用於隔熱良好的空間或場合使用。

重要安全須知

⚠ 注意

請仔細閱讀安全操作規則及使用說明。

⚠ 警告

1. 若電源線損壞，必須由製造商或其服務代理商或具有同等專業資格的人員更換，以避免危險。
2. 為防止觸電危險，切勿將本機、電線或插頭浸入水中或其他液體中。
3. 本產品可供8歲及以上兒童，以及身體、感官或精神能力較弱或缺乏經驗和知識的人士使用，前提是他們已獲得有關安全使用本產品的監督或指導，並了解相關危險。
4. 兒童不得玩耍本產品。未經監督，兒童不得進行清潔和用戶維護工作。
5. 當不使用本產品及清潔前，須從插座拔下插頭。



6. 本產品的正確處理方式

此標記表示本產品不應與其他家庭廢棄物一起棄置。為防止廢棄物不當處理可能對環境或人體健康造成危害，請負責任地回收以促進物料資源的可持續再利用。如需退回使用過的設備，請使用退貨和收集系統或聯繫購買產品的零售商。他們可將本產品進行環保回收。包裝材料是可回收的。請以環保方式處理包裝，並將其提供給可回收材料收集服務。

重要安全須知

警告

7. 將電器放在兒童或體弱人士接觸不到的地方。切勿讓他們在無人監督的情況下使用電器。
8. 僅限室內及家庭使用。
9.  警告: 為避免過熱, 切勿覆蓋暖風機。
10. 暖風機不得安裝在插座正下方。
11. 切勿在浴室、淋浴間或游泳池附近使用本暖風機。
12. 如果暖風機曾跌落, 切勿使用。
13. 如果暖風機有明顯損壞跡象, 切勿使用。
14. 將暖風機放置在水平且穩固的表面上使用。
15. 警告: 除非有持續監督, 否則切勿在無法自行離開房間的人士所處的小房間內使用本暖風機。
16. 警告: 為降低火災風險, 應將紡織品、窗簾或其他易燃材料與出風口保持至少1米的距離。
17. 注意: 本產品的某些部件可能會變得非常熱並導致灼傷。在有兒童和弱勢人士在場時需特別注意。
18. 本產品可供8歲及以上兒童, 以及身體、感官或精神能力較弱或缺乏經驗和知識的人士使用, 前提是他們已獲得有關安全使用本產品的監督或指導, 並了解相關危險。

重要安全須知

⚠ 警告

19. 風扇組裝完成後，不得再拆卸轉子葉片護罩。
 - 清潔前先拔掉風扇電源插頭。
 - 不可拆解/打開轉子護罩來清潔葉片。
 - 用微濕布擦拭風扇外殼及葉片護罩。
20. 3歲以下兒童須在持續監護下才能接觸本裝置。
21. 須遵循上述指示，包含清潔及保養章節中的說明。
22. 切勿讓兒童攀爬在暖風機上。
23. 未滿三歲的兒童必須遠離，除非有持續的監督。
24. 年齡介乎三歲至八歲的兒童，只有在該電器已放置或安裝於預定的正常操作位置，且他們已接受有關安全使用電器的指導並明白當中的危險的情況下，才可在有人監督的情況下操作電器的開關。年齡介乎三歲至八歲的兒童不得插拔電源、調校、清潔電器或進行任何用戶保養工作。

安全操作守則

1. 風扇運轉時，切勿將手指、鉛筆或其他物品伸入護網。
2. 移動風扇位置時應先斷開電源。
3. 確保風扇放置於穩固表面運作，以免傾倒。
4. 切勿在窗邊使用風扇，雨水可能導致電擊危險。
5. 僅限室內使用。

產品介紹

注意：

此說明書中的所有圖像僅適用於解釋用途。如實物與圖中插圖有任何差異，概以實物為準。

部件名稱

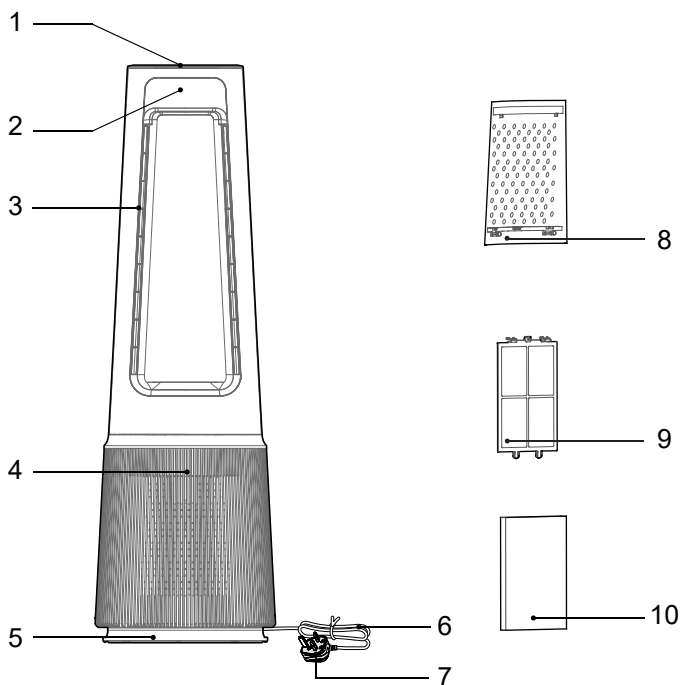

編號	部件名稱	編號	部件名稱
1	操作面板	6	電源線
2	顯示面板	7	電源插頭
3	出風口	8	進氣格柵x 2
4	指示燈	9	預濾網 x 2
5	底座	10	H13 HEPA 濾網 x 2

產品介紹

配件清單



遙控器 × 1



H13 HEPA 濾網 × 2



使用說明書 × 1

安裝說明

安裝步驟

1 拆卸進氣格柵。

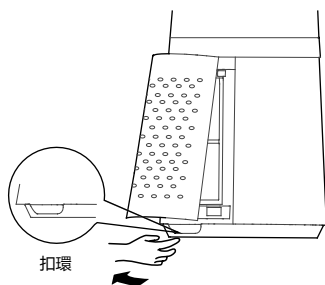

2 取出前置濾網。按壓兩側凸起部位向外拉，取出預濾網。

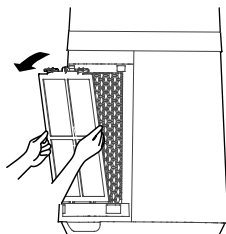

3 移除H13 HEPA濾網保護膜。

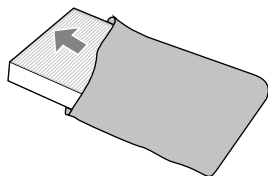

4 安裝兩個H13 HEPA 濾網。

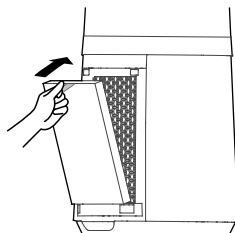

安裝說明

安裝步驟

5 安裝預濾網。

對準底部卡槽位置，扣合上方U型卡扣。

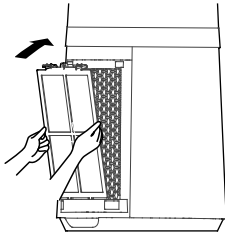

6 安裝進氣格柵。

先對準上方兩個卡扣壓緊，再按壓下方兩側，緩慢輕扣進氣格柵。

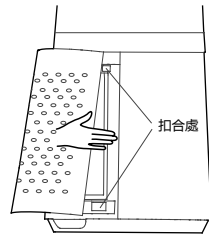

7 接通電源。

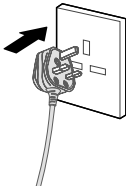

操作說明

控制面板







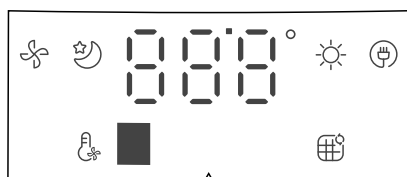



當顯示屏出現"⏻"符號時，表示機器處於待機狀態。

顯示面板



按鈕	功能說明
	輕觸 進入啟動/待機模式，電器啟動或停止。
+ -	輕觸此按鈕可設定風速/定時器。
	輕觸此按鈕可擺動30°、60°、90°及0°(停止)角度。
	輕觸此按鈕將切換至正常風速(可設定風速1-12級， 燈及藍色指示燈亮)
	開機狀態下預約關機，待機狀態下預約開機； 輕觸 按鈕並按+/- 設定定時器(顯示循環顯示0-1-2-...-12-0小時) 0小時表示取消定時。

操作說明

按鈕	功能說明
	輕觸此按鈕將切換至睡眠風(可設定風速1-3級,  燈及暖白色指示燈亮) 長按按鈕3秒可開啟/關閉指示燈。
	啟動加熱模式, 按+/-設定最高溫度(16°C-35°C)。"---°C"表示目標溫度未設定, 設備未達到安全溫度且持續運作, 若實際溫度超過設定溫度, 機器將停止運轉,  圖示閃爍15秒後保持常亮, 橙色指示燈並會亮起。(加熱模式下風速不能調節。)
	當圖示保持常亮時, 提醒需更換濾網。
	在智能風模式下,  燈及藍色指示燈亮, 風力會根據環境溫度變化自動調整。
	指示燈亮起表示機器處於待機模式且電源插頭已插入。

附加功能與維護

- 強制關機
風扇運轉期間若無任何操作, 連續運轉15小時後將自動強制關機。
- 智能記憶
當風扇關閉或斷電時, 再次通電後會以關閉或斷電前的狀態運作(不記憶定時功能)。
- 待機模式擺頭自動復位功能
待機模式下, 擺頭會自動回歸正常位置。

操作說明

遙控器按鈕說明

遙控器應在產品正前方5米內、偏差角度30度內正常使用。

電池含有多種重金屬、酸鹼等物質，可能危害人體健康；廢棄電池應單獨回收。

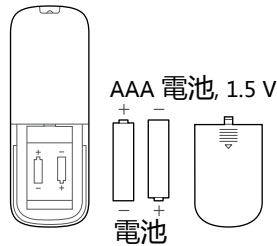
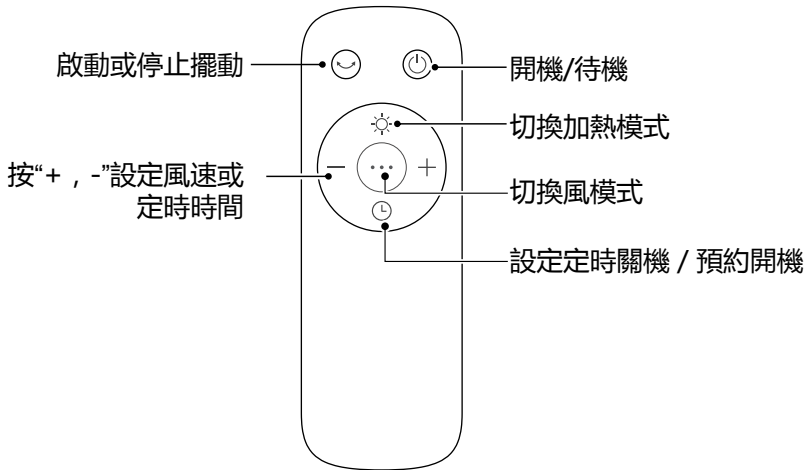

使用"AAA"型錳性或鹼性電池。切勿使用充電電池。

電池警告如下

1. 切勿將電池投入火中，電池可能會爆炸或洩漏。
2. 切勿混合使用新舊電池。
3. 切勿混合使用鹼性、標準（碳鋅）或可充電（鎳鎘）電池。
4. 不得對不可充電電池進行充電。
5. 電池必須按照正確的極性方向插入。
6. 產品中的耗盡電池應予以移除。
7. 在丟棄遙控器之前，必須將電池取出，並確保安全棄置電池。

操作說明

濾網更換

- 1 濾網型號：RBF-A/HEPA
(內含2套)。



- 2 當更換濾網的指示燈亮起時，會出現提醒您更換濾網的提示。如果未及時更換，每次啟動時都會出現該提示。



- 3 更換新濾網。

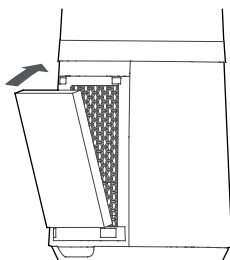

- 4 長按  按鈕3秒可關閉濾網更換指示燈。



操作說明

預濾網清潔

1 拔掉電源線。

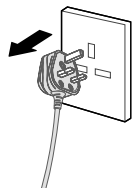

2 取出濾網。

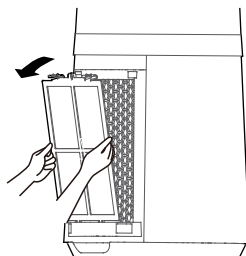

3 使用吸塵機清除灰塵。

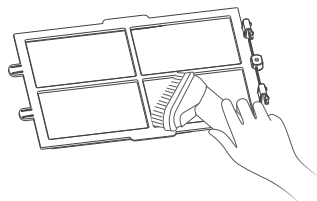

4 按相反順序安裝濾網並插上電源。

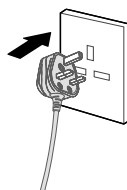

產品參數

型號	額定電壓	額定功率輸入	風扇功率	額定頻率
RBF-85AHZ	220-240V~	2000W	40W	50/60Hz

清潔及保養

風扇只需進行簡單的保養。切勿試圖自行修理。如需維修服務，應聯絡信興電器服務中心有限公司。

1. 在清潔之前，務必拔除電源插頭。
2. 塑膠部件應使用溫和的肥皂和濕布或海綿清潔。用乾布徹底清除肥皂泡沫。
3. 須確保水或其他液體不會進入摩打內部。

疑難排解

使用你的設備期間，可能會出現錯誤和故障。以下表格列出了可能的故障原因及解決方法，以協助你排除故障。建議你仔細閱讀下表，以節省致電信興電器服務中心有限公司可能產生的時間和費用。

問題	原因	解決方法
機器安裝後無法正常運作	• 電源線未插入或接觸不良。	確保插頭已正確插入插座。
	• 機身上的開關未開啟。	打開機身上的開關。
遙控器無法使用	• 電池耗盡。	更換電池。
	• 遙控器正在距離風扇超過5米的地方使用。	將遙控器靠近風扇使用，並確保其正對著顯示面板。

特別聲明

1. 本資料上所有內容經過認真核對，如有任何印刷及內容上的誤解，本公司將保留解釋權。
2. 本產品若有技術改進，會編進新版說明書中，恕不另行通知；產品外觀及顏色如有改動，則以實物為準。
3. 用戶如需要電子版使用說明書，請致電信興電工工程有限公司熱線查詢：2861 2767。

售後服務

由購買日期起之一年保修期內，經信興電器服務中心有限公司之服務人員證實乃在正常使用之情況下發生者，本公司將提供免費修理及更換零件。經更換之任何損壞零件，將歸屬本公司。保修範圍不包括修理或更換產品之附件、電源線及機殼等，如有需要服務時，用戶須另付費用。

用戶請於維修時出示購買收據 / 換購收據及保修證，如有任何疑問，請致電信興電器服務中心有限公司熱線查詢：2406 5666。

如在保修證內所列之電器：

- 1) 曾經被非本公司技術人員明顯地或非明顯地進行改裝、更改或修理
- 2) 曾經被錯誤或不適當或疏忽使用、或因液體浸蝕、水濺、不正常供電、天災、意外或外來因素造成損壞
- 3) 並非安裝在陸上固定地點
- 4) 不當安裝位置影響正常操作
- 5) 非工商業用型號產品，被用作工商業用途
- 6) 用戶搬遷地址或更換物主而未能及時通知信興電器服務中心有限公司者，保修證將自動失效。



RBF-85AHZ

Air Purifying Bladeless Fan Heater

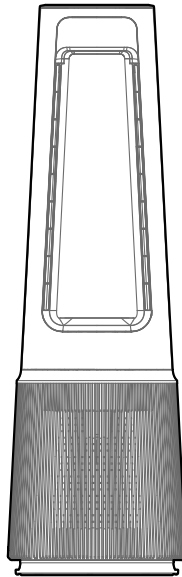

For Household Use Only

OPERATION MANUAL

- **WARNING:** Before using this product, please read this manual carefully and keep it for future reference.
- The design and specifications are subject to change without prior notice for product improvement. Consult with your dealer or manufacturer for details.
- The diagram above is for reference. Please take the appearance of the actual product as the standard.
- The device is only suitable for well insulated spaces or occasion use.

IMPORTANT SAFETY INSTRUCTIONS

Caution

Read Rules for Safe Operation and Instructions Carefully.

WARNING

1. If the supply cord is damaged, it must be replaced by manufacturer or its service agent or a similarly qualified person in order to avoid a hazard.
2. To protect against the risk of electrical shock, do not immerse the unit, cord or plug in water or other liquid.
3. This appliance can be used by children aged from 8 years and above and persons with reduced physical, sensory or mental capabilities or lack of experience and knowledge if they have been given supervision or instruction concerning use of the appliance in a safe way and understand the hazards involved.
4. Children shall not play with the appliance. Cleaning and user maintenance shall not be made by children without supervision.
5. When the appliance is not in use and before cleaning, unplug the appliance from the outlet.



6.  Correct Disposal of this product

This marking indicates that this product should not be disposed with other household wastes. To prevent possible harm to the environment or human health from uncontrolled waste disposal, recycle it responsibly to promote the sustainable reuse of material resources. To return your used device, please use the return and collection systems or contact the retailer where the product was purchased. They can take this product for environmental safe recycling. The packaging material is recyclable. Dispose of the packaging in an environmentally friendly manner and make it available for the recyclable material collection-service.

IMPORTANT SAFETY INSTRUCTIONS

WARNING

7. Keep electrical appliances out of reach from Children or infirm persons. Do not let them use the appliances without supervision.
8. Indoor and household use only.
9.  WARNING: In order to avoid overheating, do not cover the heater.
10. The Heater is not located immediately below a socket outlet.
11. Do not use this heater in the immediate surroundings of a bath, a shower or a swimming pool.
12. Do not use this heater if it has been dropped.
13. Do not use if there are visible signs of damage to the heater.
14. Use this heater on a horizontal and stable surface.
15. WARNING: Do not use this heater in small rooms when they are occupied by persons not capable of leaving the room on their own, unless constant supervision is provided.
16. WARNING: To reduce the risk of fire, keep textiles, curtains, or any other flammable material a minimum distance of 1 m from the air outlet.
17. CAUTION — Some parts of this product can become very hot and cause burns. Particular attention has to be given where children and vulnerable people are present.
18. This appliance can be used by children aged from 8 years and above and persons with reduced physical, sensory or mental capabilities or lack of experience and knowledge if they have been given supervision or instruction concerning use of the appliance in a safe way and understand the hazards involved.
19. When the fan was assembled, the rotor blade guard shall not be taken off anymore.

IMPORTANT SAFETY INSTRUCTIONS

WARNING

- Prior cleaning unplug the fan.
 - The rotor guard shall not be disassembled/opened to clean the rotor blades.
 - Wipe the fan enclosure and rotor blade guard with a slightly damp cloth.
20. Keep children under the age of 3 away from this device unless they are constantly supervised.
21. Follow the instructions above, including the instructions in the section about cleaning and maintenance.
22. Do not allow children climb on the heater.
23. Children of less than 3 years should be kept away unless continuously supervised.
24. Children aged from 3 years and less than 8 years shall only switch on/off the appliance provided that it has been placed or installed in its intended normal operation position and they have been given supervision or instruction concerning use of the appliance in a safe way and understand the hazards involved. Children aged from 3 years and less than 8 years shall not plug in, regulate and clean the appliance or perform user maintenance.

RULES FOR SAFE OPERATION

1. Never insert fingers, pencils, or any other object through the grille when fan is running.
2. Disconnect fan when moving from one location to another.
3. Be sure fan is on a stable surface when operating to avoid overturning.
4. DO NOT use fan in window, rain may create electrical hazard.
5. Indoor use only.

PRODUCT INTRODUCTION

Note:

All the pictures in this manual are for explanation purpose only. Any discrepancy between the real object and the illustration in the drawing shall be subject to the real subject.

Parts name

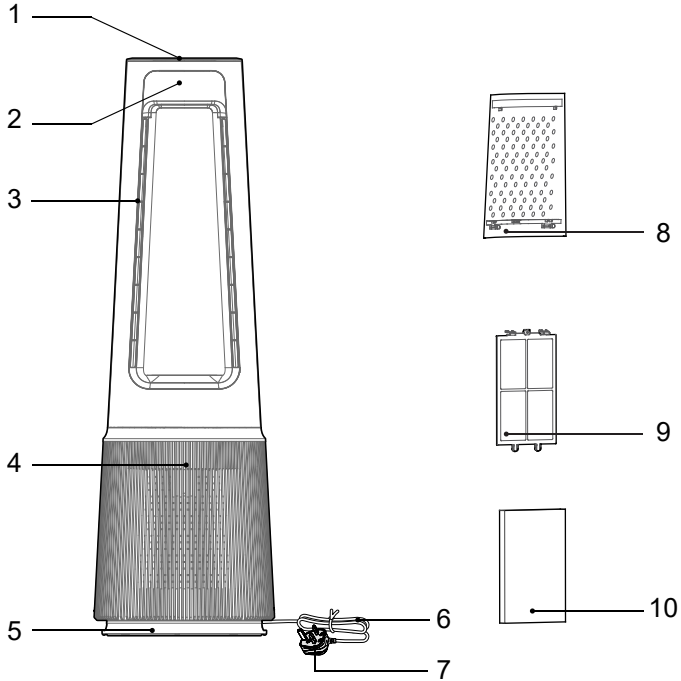

NO.	Description	NO.	Description
1	Operation panel	6	Power cord
2	Display panel	7	Power plug
3	Air outlet	8	Inlet grille x 2
4	Indicator light	9	Pre-filter x 2
5	Base	10	H13 HEPA filter x 2

PRODUCT INTRODUCTION

Parts list

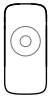

Remote Controller ×1



H13 HEPA filter × 2



Operation Manual × 1

INSTALLATION INSTRUCTIONS

Installation steps

1 Remove the air inlet grille.

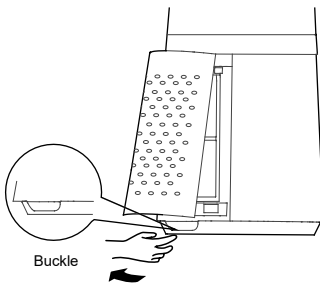

2 Take out the pre-filter
Press the raised part on both sides to pull it outwards, and take out the pre-filter.

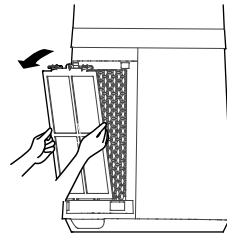

3 Remove the protective film of the H13 HEPA filter.

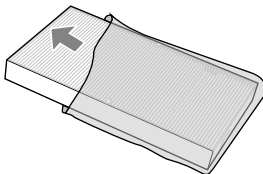

4 Install the H13 HEPA filter x 2.

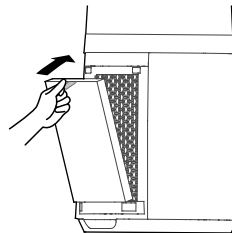

INSTALLATION INSTRUCTIONS

Installation steps

5 Install the pre-filter

Align the slot position at the bottom, and buckle up the upper U-shaped buckle.

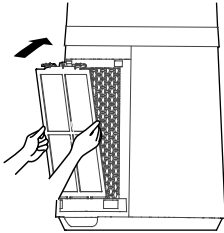

6 Install the air inlet grille

Align the upper two buckles and press them tightly, then press the two sides at lower part, slowly and gently buckle the air inlet grille.

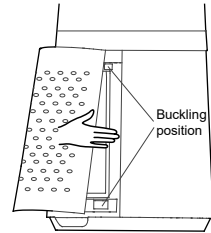

7 Plug power supply.

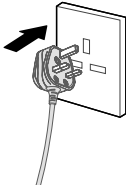

OPERATION INSTRUCTIONS

Control panel







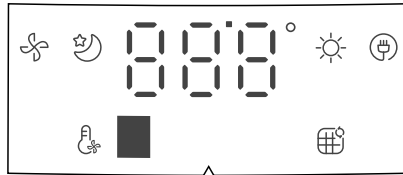



When the display interface shows " □ ", it means the machine is in standby state.

Display panel



Button	Function Description
	Touch to enter Startup/Standby, the appliance startup or stop.
+ —	Touch this button to set wind speed / timer.
	Touch this button to swing at the angle of 30°, 60°, 90° and 0°(Stop).
	Touch this button will switch to Normal wind (adjustable wind speed 1-12, lights up and blue indicator lights up).
	Schedule to shut down in the power-on state, and schedule to start up in the standby state; Touch button and press +/- to set the timer (the display cycles among 0-1-2-...-12-0h); 0h means that the timer is canceled.

INSTRUCTIONS

Button	Function Description
	Touch this button will switch to Sleep wind (adjustable wind speed 1-3,  lights up and white indicator lights up); Press and hold the button for 3 seconds to turn on/turn off the indicator light.
	Activate heating mode, press +/- to set the highest temperature (16°C-35°C). “---°C” indicates target temperature not set, the appliance does not reach the safe temperature and continues to work, if the actual temperature exceeds the set temperature, the machine will stop, the  icon flashes for 15 seconds and then stays on, and yellow indicator lights up. (The fan speed cannot be adjusted in heating mode.)
	When the icon stays on, it reminds to replace the filter.
	In smart wind mode,  lights up and blue indicator lights up, and the wind power is automatically adjusted according to changes in ambient temperature.
	The indicator light turns on indicating that the machine is in standby mode and the power plug is plugged in.

Additional Features and Maintenance

- **Forced shutdown**
There is no operation during the running of the fan, after 15 hours of continuous operation, the fan will be forced to shut down automatically.
- **Intelligent memory**
When the fan is turned off or powered off, it will run in the state before turning off or power off when the power is powered on again (the timing function is not memorized).
- **Automatic reset function for shaking head in standby mode**
In standby mode, shaking head automatically returns to normal.

INSTRUCTIONS

Remote control button description

The remote control should be normally used within 5 meters of the front of the product and 30 degrees of the deviation angle.

The battery contains many heavy metals, acids and bases, etc., which may threaten human's health; Waste batteries should be recycled separately.

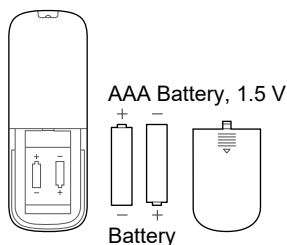
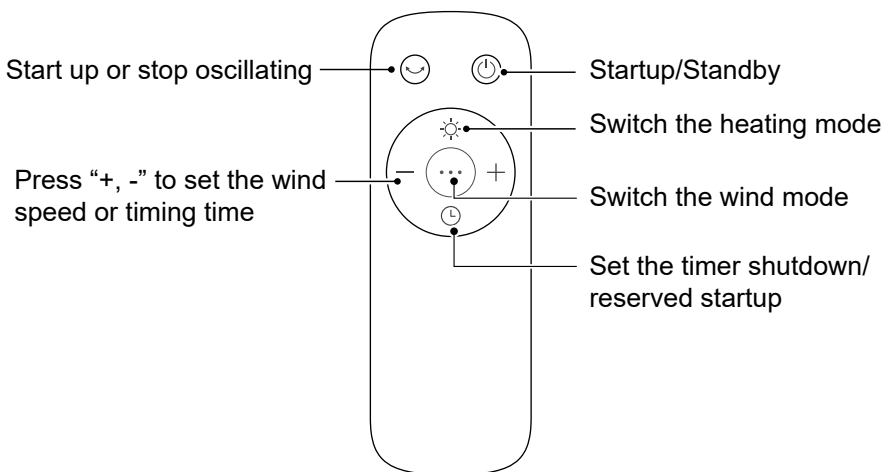

Use manganese or alkaline batteries of type "AAA".
DO not use rechargeable batteries.

Battery Warning As Below

1. Do not dispose of batteries in fire, batteries may explode or leak.
2. Do not mix old and new batteries.
3. Do not mix alkaline, standard (carbon-zinc) or rechargeable (Ni-Cd) batteries.
4. Non-rechargeable batteries are not to be recharged.
5. Batteries are to be inserted with the correct polarity.
6. Exhausted batteries are to be removed from the product.
7. The batteries must be removed from the remote control before it is scrapped and the batteries are disposed of safety.

INSTRUCTIONS

Filter replacement

- 1 Filter model: RBF-A/HEPA
(including 2 sets).



- 2 When the indicator light for replacement of filter is on, the prompt that reminds you of filter replacement will appear. If it is not replaced in time, the prompt will appear during each startup.



- 3 Replace a new filter.

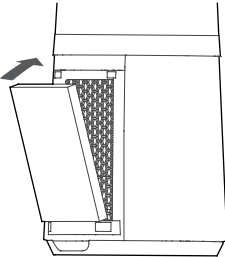

- 4 Press and hold the  button for 3 seconds to turn off the indicator light for filter replacement.



INSTRUCTIONS

Pre-Filter cleaning

1 Unplug the power cord.

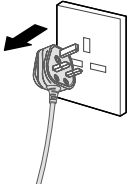

2 Take out the filter.

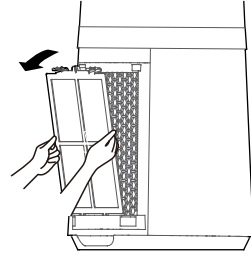

3 Remove the dust with vacuum cleaner.

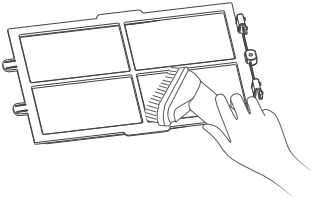

4 Install the machine in reverse order and plug power supply.

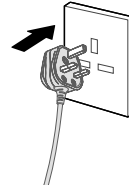

PRODUCT PARAMETER

Model	Rated Voltage	Rated Input Power	Power For Fan	Rated Frequency
RBF-85AHZ	220-240V~	2000W	40W	50/60Hz

CLEANING AND MAINTENANCE

The fan requires minimal maintenance. Do not try to fix it by yourself. Please contact Shun Hing Electric Service Centre Ltd. if service is needed.

1. Be sure to unplug from the electrical supply source before cleaning.
2. Plastic parts should be cleaned with mild soap and a damp cloth or sponge. Thoroughly remove soapsuds with dry cloth.
3. Be sure not to make water or other liquid enter inside the motor.

TROUBLESHOOTING

Operation of your appliance can lead to errors and malfunctions. The following tables contain possible causes and solution for resolving malfunction. It is recommended to read the table below carefully in order to save your time and money that may cost for calling to Shun Hing Electric Service Centre Ltd.

Problem	Cause	Solution
The machine does not work properly after installed	• The power cable is not plugged in or has poor contact.	Make sure the plug is properly inserted into the socket.
	• The switch on the body is not turned on.	Turn on the switch on the body.
The remote does not work	• The battery exhausted.	Replace the battery.
	• The remote is being used more than 5 meters away from the fan.	Use the remote closer to the fan and make sure it is pointing directly at the display panel.

SPECIAL AVOWAL

1. The information above has been checked. Our company reserves the hermeneutic power to any printing errors or misunderstanding on the content.
2. If there are technical improvements on the appliance, the operation manual will be updated without any prior notice. The product appearance and color are subject to the actual appliance.
3. The e-copy of operation manual can be sent by e-mail on requested, please call Shun Hing Electric Works & Engineering Co. Ltd. hotline at 2861 2767.

AFTER SALES SERVICES

For any defect, in the judgment of technician from Shun Hing Electric Service Centre Limited, caused under normal use, we are responsible for repairing or replacing parts of the said electrical appliance free of charge within one year guarantee period commencing from the date of purchase. Any defective part which has been replaced shall become our property. Guarantee service does not cover the repair or replacement of accessories, power cord or cabinet, etc. Additional charges shall be levied if services are required. Please present the official invoice and the guarantee certificate with the sales point's chop or the redemption center's chop for free maintenance. For enquiries, please call Shun Hing Electric Service Centre Limited hotline at 2406 5666. Free guarantee service will not be provided to the appliance if: 1) it has been explicitly or implicitly modified, tampered with, altered or repaired in any way by persons other than technicians of the Company. Or 2) it has been damaged through misuse, negligence, liquid ingress or corrosion, power interruption, natural calamities or accident or external factors. Or 3) it is not a fixed installation on land. Or 4) the normal operation of the appliance is affected by improper installation. Or 5) the domestic model of appliance is used for industrial or commercial purpose. Or 6) the change of location or ownership of the product and did not inform Shun Hing Electric Service Centre Limited.

信興電工工程有限公司

SHUN HING ELECTRIC WORKS & ENGINEERING CO., LTD

辦公室: 香港九龍尖沙咀東部麼地道 67 號半島中心 9 樓

OFFICE: 9/F, PENINSULA CENTRE, 67 MODY ROAD, TSIMSHATSUI EAST, KOWLOON, HONG KONG

電話 TEL: (852) 2861 2767 傳真 FAX: (852) 2865 6706

網址 WEBSITE: www.rasonic.hk 電郵 EMAIL: shew@shunhinggroup.com

保養及維修 MAINTENANCE AND REPAIR SERVICE

信興電器服務中心有限公司

SHUN HING ELECTRIC SERVICE CENTRE LTD.

辦公室: 香港新界葵涌勝耀街 2 號信興中心 11 樓

OFFICE: 11TH FLOOR, SHUN HING CENTRE, 2 SHING YIU STREET, KWAI CHUNG, NEW TERRITORIES, HONG KONG

電話 TEL: (852) 2406 5666

傳真 FAX: (852) 2408 0316

網址 WEBSITE: www.shesc.com

消耗品/附件銷售熱線 CONSUMABLES/ ACCESSORIES SALES HOTLINE

電話 TEL: (852) 2406 5666

客戶服務中心 CUSTOMER SERVICE CENTRES

香港新界葵涌勝耀街 2 號信興中心 1 樓

1ST FLOOR, SHUN HING CENTRE, 2 SHING YIU STREET, KWAI CHUNG, NEW TERRITORIES, HONG KONG

電話 TEL: (852) 2406 5439

傳真 FAX: (852) 2408 1389

澳門慕拉士大馬路 193-199 號南嶺工業大廈 5 樓 1 座

AVENIDA DE VENCESLAU DE MORAIS, NO. 193-199, 5 ANDAR-I, EDF. INDUSTRIAL NAM LENG, MACAU

電話 TEL: (853) 2836 2928

傳真 FAX: (853) 2833 6405

有關最新之客戶服務中心資訊, 請參閱信興服務中心網址 www.shesc.com 或致電維修服務熱線查詢。

For the latest information of customer service centres, please visit www.shesc.com or call us at our hotline.

